

DYNAMICS

CONTENTS

- Winds and Weather Maps 290
 - Height Contours on Isobaric Surfaces 290
 - Plotting Winds 291
- Newton's Second Law of Motion 292
 - Lagrangian Momentum Budget 292
 - Eulerian Momentum Budget 293
- Horizontal Forces 294
 - Advection 294
 - Pressure-Gradient Force 295
 - Centrifugal Force 296
 - Coriolis Force 297
 - Turbulent-Drag Force 300
 - Summary of Forces 301
- Equations of Horizontal Motion 301
- Horizontal Winds 302
 - Geostrophic Wind 302
 - Gradient Wind 304
 - Boundary-Layer Wind 307
 - Boundary-Layer Gradient (BLG) Wind 309
 - Cyclostrophic Wind 311
 - Inertial Wind 312
 - Antitriptic Wind 312
 - Summary of Horizontal Winds 313
- Horizontal Motion 314
 - Equations of Motion — Revisited 314
 - Scales of Horizontal Motion 315
- Vertical Forces and Motion 315
- Mass Conservation 317
 - Continuity Equation 317
 - Incompressible Continuity Equation 318
 - Boundary-Layer Pumping 319
- Kinematics 320
- Measuring Winds 321
- Summary 322
 - Threads 322
- Exercises 322
 - Numerical Problems 322
 - Understanding & Critical Evaluation 324
 - Web-Enhanced Questions 326
 - Synthesis Questions 327

10 We use winds to power our wind turbines, push our sailboats, cool our houses, and dry our laundry on the clothesline. But winds can also be destructive — in hurricanes, thunderstorms, or mountain downslope windstorms. We design our bridges and skyscrapers to withstand wind gusts. Airplane flights are planned to compensate for headwinds and crosswinds.

Winds are driven by forces acting on air. But these forces can be altered by heat and moisture carried by the air, resulting in a complex interplay we call weather. The relationship between forces and winds is called **atmospheric dynamics**. Newtonian physics describes atmospheric dynamics well.

Pressure, drag, and advection are atmospheric forces that act in the horizontal. Other forces, called apparent forces, are caused by the Earth's rotation (Coriolis force) and by turning of the wind around a curve (centrifugal and centripetal forces).

These different forces are present in different amounts at different places and times, causing large variability in the winds. For example, Fig. 10.1 shows changing wind speed and direction around a low-pressure center. In this chapter we explore forces, winds, and the dynamics that link them.

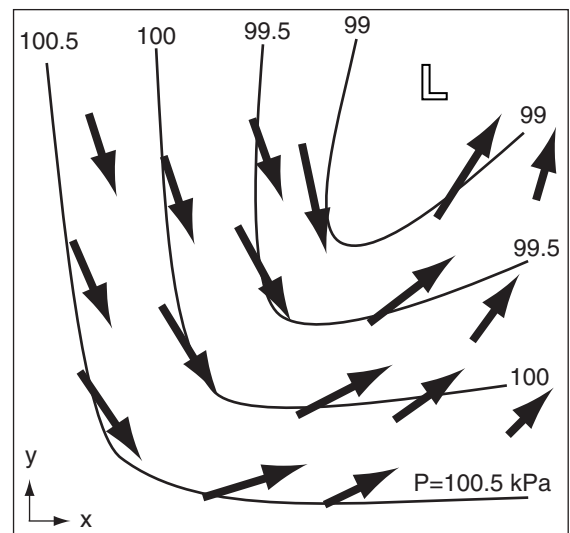
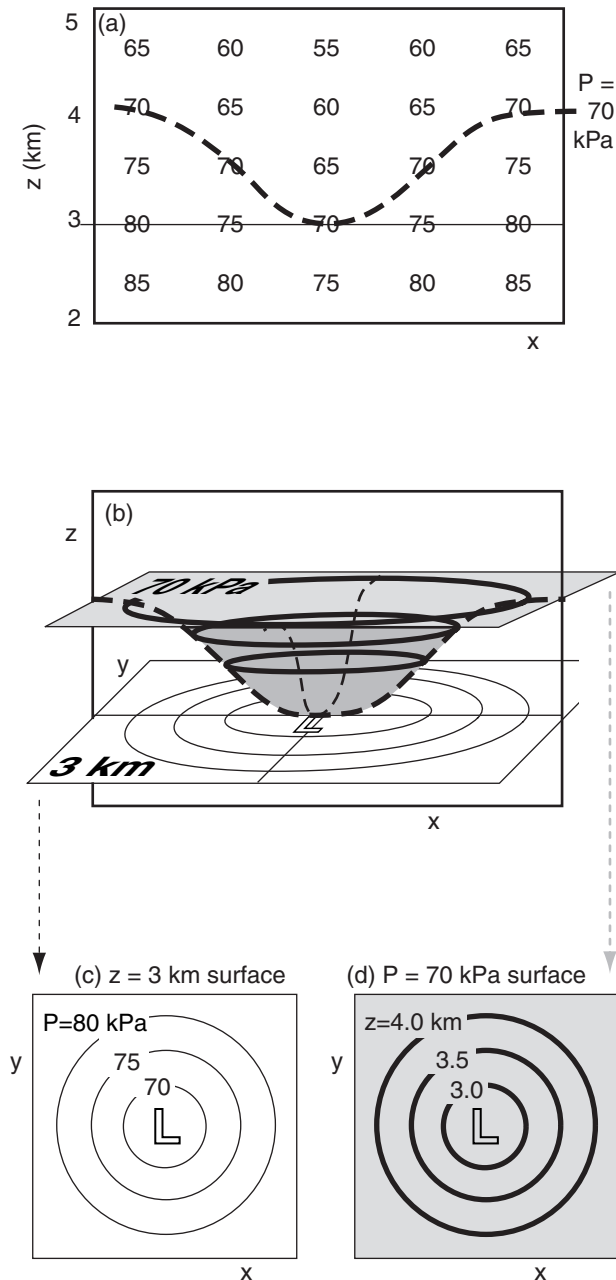

Figure 10.1 Sketch of sea-level pressure (thin lines are isobars) & the resulting near-surface winds (arrows). “L” is low pressure center.

**Figure 10.2**

(a) Vertical slice through atmosphere, showing pressure values (kPa). Thick dashed line is the 70 kPa isobar. Thin straight line is the 3 km height contour. The location of lowest pressure on the height contour corresponds to the location of lowest height of the isobar. (b) 3-D sketch of the same 70 kPa isobaric surface (shaded), and 3 km height surface (white). (c) Pressures intersected by the 3 km constant height surface. (d) Heights crossed by the 70 kPa surface. The low-pressure center (L) in (c) matches the low-height center in (d).

WINDS AND WEATHER MAPS

Height Contours on Isobaric Surfaces

Pressure-gradient force is the most important force because it is the only one that can drive winds in the horizontal. Other horizontal forces can alter an existing wind, but cannot create a wind from calm air. All the forces, including pressure-gradient force, are explained in the next sections. However, to understand the pressure gradient, we must first understand pressure and its atmospheric variation.

We can create weather maps showing values of the pressures measured at different horizontal locations all at the same altitude, such as at mean-sea-level (MSL). Such a map is called a **constant-height map**. However, one of the peculiarities of meteorology is that we can also create maps on other surfaces, such as on a surface connecting points of equal pressure. This is called an **isobaric map**. Both types of maps are used extensively in meteorology, so you should learn how they are related.

In Cartesian coordinates (x, y, z) , height z is geometric distance above some reference level, such as the ground or sea level. Sometimes we use geopotential height H in place of z , giving a coordinate set of (x, y, H) (see Chapter 1). However, an alternative coordinate system can use pressure P as the vertical coordinate, because pressure decreases monotonically with increasing height. **Pressure coordinates** consist of (x, y, P) .

A **monotonic** variable is one that changes only in one direction. For example, it increases or is constant, but never decreases. Or it decreases or is constant, but never increases. Pressure in the atmosphere always decreases with increasing height.

A surface connecting points of equal pressure is an **isobaric surface**. In low-pressure regions, this surface is closer to the ground than in high-pressure regions (Fig. 10.2b). Thus, this surface curves up and down through the atmosphere. Although isobaric surfaces are not flat, we draw them as flat weather maps on the computer screen or paper (Fig. 10.2d).

Low pressures on a constant-height map correspond to low heights on a constant pressure surface. High pressures on a constant height map correspond to high heights on a constant pressure surface. Similarly, regions on a constant-height map that have tight **packing** (close spacing) of isobars correspond to regions on isobaric maps that have tight packing of height contours, both of which are regions of strong pressure gradients that can drive strong winds. This one-to-one correspondence of both types of maps (Figs. 10.2c & d) makes it easier for you to use them interchangeably.

It is impossible for two different isobaric surfaces to cross each other. Also, these surfaces never fold back on themselves, because pressure decreases monotonically with height. However, they can intersect the ground, such as frequently happens in mountainous regions.

Isobaric charts will be used extensively in the remainder of this book when describing upper-air features (mostly for historical reasons; see Focus box). Fig. 10.3 is a sample weather map showing height contours of the 30 kPa isobaric surface.

Plotting Winds

Symbols on weather maps are like musical notes in a score — they are a shorthand notation that concisely expresses information. For winds, the symbol is an arrow with feathers (or barbs and pennants). The tip of the arrow is plotted over the observation (weather-station) location, and the arrow shaft is aligned so that the arrow points toward where the wind is going. The number and size of the feathers indicates the wind speed (Table 10-1, copied from Table 9-9). Fig. 10.3 illustrates wind barbs.

Symbol	Wind Speed	Description
⊙	calm	two concentric circles
—	1 - 2 speed units	shaft with no barbs
└─	5 speed units	a half barb (half line)
└─┬─	10 speed units	each full barb (full line)
└─┬─┬─	50 speed units	each pennant (triangle)

- The total speed is the sum of all barbs and pennants. For example, └─┬─┬─ indicates a wind from the west at speed 75 units. Arrow tip is at the observation location.
- CAUTION: Different organizations use different speed units, such as knots, m/s, miles/h, km/h, etc. Look for a legend to explain the units. When in doubt, assume knots — the WMO standard. For unit conversion, a good approximation is 1 m/s ≈ 2 knots.

Solved Example
 Draw wind barb symbol for winds from the:
 (a) northwest at 115 knots; (b) northeast at 30 knots.

Solution
 (a) 115 knots = 2 pennants + 1 full barb + 1 half barb.
 (b) 30 knots = 3 full barbs



(a)



(b)

Check: Consistent with Table 10-1.
Discussion: Feathers (barbs & pennants) should be on the side of the shaft that would be towards low pressure if the wind were geostrophic.

FOCUS • Why use isobaric maps?

Constant pressure charts are used for five reasons. First, the old **radiosonde** (consisting of weather sensors hanging from a free helium balloon that rises into the upper troposphere and lower stratosphere) measured pressure instead of altitude, so it was easier to plot their measurements of temperature, humidity and wind on an isobaric surface. For this reason, **upper-air charts** (i.e., showing weather above the ground) traditionally have been drawn on isobaric maps.

Second, aircraft altimeters are really pressure gauges. Aircraft assigned by air-traffic control to a specific “altitude” above 18,000 feet MSL will actually fly along an isobaric surface. Many weather observations and forecasts are motivated by aviation needs.

Third, pressure is a measure of mass in the air, so every point on an isobaric map has the same number of air molecules above it.

Fourth, an advantage of using equations of motion in pressure coordinates is that you do not need to consider density, which is not routinely observed.

Fifth, some weather forecast models use pressure coordinate systems in the vertical.

However, more and more routine upper-air soundings around the world are being made with modern **GPS (Global Positioning System)** (satellite triangulation method) sondes that can measure geometric height as well as pressure. Also, some of the modern weather forecast models do not use pressure as the vertical coordinate. In the future, we might see the large government weather data centers starting to produce upper-air weather maps on constant height surfaces.

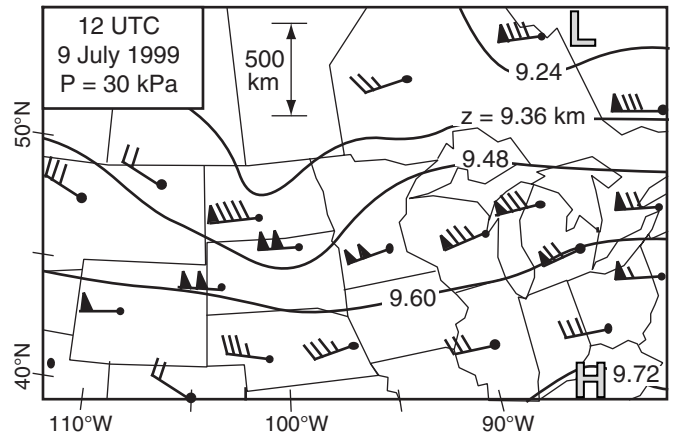

Figure 10.3
 Weather map for a 30 kPa constant pressure surface over central N. America. Solid contours show height z (km) of this surface above mean sea level (MSL). Hence, this is called a “30 kPa height chart”. Wind barbs (Table 10-1) show wind observations in knots (2 knots ≈ 1 m/s). The relative maxima and minima heights are labeled as H (high heights) and L (low heights).

FOCUS • In Newton's Own Words

Newton's laws of motion, in his own words, are given below. Actually, his original words were Latin, the language of natural philosophy (science) at that time (1687). Here is the translation from Newton's *Philosophiæ Naturalis Principia Mathematica* ("Mathematical Principles of Natural Philosophy"):

“Law I. Every body perseveres in its state of being at rest or of moving uniformly straight forward, except inasmuch as it is compelled by impressed forces to change its state.

“Law II. Change in motion is proportional to the motive force impressed and takes place following the straight line along which that force is impressed.

“Law III. To any action, there is always a contrary, equal reaction; in other words, the actions of two bodies each upon the other are always equal and opposite in direction.

“Corollary 1. A body under the joint action of forces traverses the diagonal of a parallelogram in the same time as it describes the sides under their separate actions.”

Solved Example

A 1500 kg car accelerates from 0 to 60 mph (0 to 96.6 km/h) in 9 seconds, heading south. (a) Find its average acceleration. (b) What magnitude and direction of force acted on it to make it accelerate?

Solution

Given: $\vec{V}_{\text{initial}} = 0$, $\vec{V}_{\text{final}} = 60 \text{ mph} = 27 \text{ m/s}$
 $t_{\text{initial}} = 0$, $t_{\text{final}} = 9 \text{ s}$. Direction is south.
 $m = 1500 \text{ kg}$.

Find: $\vec{a} = ? \text{ m}\cdot\text{s}^{-2}$, $\vec{F} = ? \text{ N}$

(a) Use eq. (10.2): $\vec{a} = \frac{\Delta \vec{V}}{\Delta t}$
 $= (27 - 0 \text{ m/s}) / (9 - 0 \text{ s}) = \mathbf{3 \text{ m}\cdot\text{s}^{-2} \text{ to the south}}$

(b) Use eq. (10.1): $\vec{F} = (1500 \text{ kg}) \cdot (3 \text{ m}\cdot\text{s}^{-2})$
 $= \mathbf{4500 \text{ N to the south}}$
 (From Appendix A, recall that $1 \text{ N} = 1 \text{ kg}\cdot\text{m}\cdot\text{s}^{-2}$)

Check: Units OK. Physics OK.

Discussion: If the car falls off a cliff, gravity would accelerate it at $g = -9.8 \text{ m}\cdot\text{s}^{-2}$, where the negative sign denotes the downward direction.

NEWTON'S SECOND LAW OF MOTION**Lagrangian Momentum Budget**

Forces, winds, and acceleration are vectors possessing both magnitude and direction. **Newton's second law of motion** (often shortened to **Newton's second law**) states that a vector force \vec{F} acting on an object such as an air parcel of mass m causes it to accelerate \vec{a} in the same direction as the applied force:

$$\vec{F} = m \cdot \vec{a} \quad \bullet(10.1)$$

Acceleration is defined as the rate of change of velocity with time t :

$$\vec{a} = \frac{\Delta \vec{V}}{\Delta t} \quad (10.2)$$

where \vec{V} is the vector wind velocity.

Combining eqs. (10.1) and (10.2) give

$$\vec{F} = m \cdot \frac{\Delta \vec{V}}{\Delta t} \quad (10.3a)$$

If mass is constant, then the equation can be written as:

$$\vec{F} = \frac{\Delta(m \cdot \vec{V})}{\Delta t} \quad (10.3b)$$

But mass times velocity equals momentum. Thus, eq. (10.3b) describes the change in momentum with time following the air parcel; namely, it is the **Lagrangian momentum budget**.

Rearranging eq. (10.3a) gives a forecast equation for the wind velocity:

$$\frac{\Delta \vec{V}}{\Delta t} = \frac{\vec{F}_{\text{net}}}{m} \quad (10.4)$$

The subscript “net” implies that there might be many forces acting on the air parcel, and we need to consider the vector sum of all forces in eq. (10.4), as given by Newton's Corollary 1 (see Focus box).

For situations where $\vec{F}_{\text{net}}/m = 0$, eq. (10.4) tells us that the flow will maintain constant velocity due to **inertia**. Namely, $\Delta \vec{V} / \Delta t = 0$ implies that $\vec{V} = \text{constant}$ (not that $\vec{V} = 0$).

Eulerian Momentum Budget

For wind forecasts over a fixed location such as a town or lake, use an **Eulerian** reference frame. Define a local Cartesian coordinate system with x increasing toward the local East, y toward the local North, and z up (see Chapter 1).

Wind components in a Cartesian framework can be found by rewriting the vector equation (10.4) as three separate scalar equations: one for the west-to-east wind component (U), one for the south-to-north component (V), and one for the vertical component (W):

$$\frac{\Delta U}{\Delta t} = \frac{F_{x \text{ net}}}{m} \quad \bullet(10.5a)$$

$$\frac{\Delta V}{\Delta t} = \frac{F_{y \text{ net}}}{m} \quad \bullet(10.5b)$$

$$\frac{\Delta W}{\Delta t} = \frac{F_{z \text{ net}}}{m} \quad \bullet(10.5c)$$

where subscripts (x , y , z) indicate the component of the net vector force toward the (east, north, up), respectively. Relationships between the horizontal “speed and direction” method of representing a vector wind versus the “ U and V component” method were given in Chapter 1.

Recall that $\Delta U/\Delta t = [U(t+\Delta t) - U(t)]/\Delta t$. Thus, we can rewrite eqs. (10.5) as forecast equations:

$$U(t + \Delta t) = U(t) + \frac{F_{x \text{ net}}}{m} \cdot \Delta t \quad \bullet(10.6a)$$

$$V(t + \Delta t) = V(t) + \frac{F_{y \text{ net}}}{m} \cdot \Delta t \quad \bullet(10.6b)$$

$$W(t + \Delta t) = W(t) + \frac{F_{z \text{ net}}}{m} \cdot \Delta t \quad \bullet(10.6c)$$

These equations are often called the **equations of motion**. Together with the continuity equation (later in this chapter), the equation of state (ideal gas law from Chapter 1), and the energy budget equations in the Heat and Moisture chapters, they describe the dynamic and thermodynamic state of the air.

To forecast winds [$U(t+\Delta t)$, $V(t+\Delta t)$, $W(t+\Delta t)$] at some future time, we must know the winds now [$U(t)$, $V(t)$, $W(t)$], and the forces acting on the air. Mathematically, this is known as an **initial-value problem**, because we must know the initial winds to forecast the future winds. Even numerical weather forecast models (see the NWP chapter) must start with an **analysis** of current weather observations.

Average horizontal winds are often 100 times stronger than vertical winds, except in thunderstorms and near mountains. We will focus on horizontal forces and winds first, and return to vertical winds later in this chapter.

Solved Example

If $F_{x \text{ net}}/m = 1 \times 10^{-4} \text{ m}\cdot\text{s}^{-2}$ acts on air initially at rest, then what is the final wind speed after 10 minutes?

Solution

Given: $U(0) = 0$, $F_{x \text{ net}}/m = 1 \times 10^{-4} \text{ m}\cdot\text{s}^{-2}$, $\Delta t = 600 \text{ s}$
Find: $U(\Delta t) = ? \text{ m/s}$. Assume: $V=0$.

$$\begin{aligned} \text{Use eq. (10.6a): } U(t+\Delta t) &= U(t) + \Delta t \cdot (F_{x \text{ net}}/m) \\ &= 0 + (600\text{s}) \cdot (1 \times 10^{-4} \text{ m}\cdot\text{s}^{-2}) = \mathbf{0.06 \text{ m/s}}. \end{aligned}$$

Check: Units OK. Physics OK.

Discussion: Not very fast, but over many hours it becomes large. Positive U means it is toward the east.

ON DOING SCIENCE • Be Creative

Isaac Newton grew up on his mother’s farm at Woolsthorpe, and built model windmills, clocks, and sundials. His grades in school were OK. He got into fights with his classmates, and carved his name in his desk. His schoolmaster saw a spark of talent in Isaac, and suggested to his mother that Isaac should go to college, because he would never be a good farmer.

At age 18, Isaac Newton went to Cambridge University in England in 1661, and after working at odd jobs to pay his way, finally graduated with a B.A. in 1665. Later that year the plague hit, killing 10% of the London population in three months. For fear that the plague would spread, Cambridge Univ. was closed until 1667. Isaac and the other students went home.

He continued his scientific studies in seclusion at his mother’s farmhouse during the 18 months that school was closed. During this period, at age 23 to 24, he laid the groundwork for many of his major discoveries. This included the laws of motion, the study of optics, the invention of the reflecting telescope, the explanation for the orbits of planets, the understanding of gravity, and the co-invention of calculus.

Often the most creative science, music, literature, and art are done by young men and women who have not been biased and (mis)directed by studying the works of others too much. Such knowledge of past work will often subconsciously steer one’s research in the directions that others have already taken, which unfortunately discourages novel ideas.

Be creative, and learn from your mistakes. So what if you “re-invent the wheel”, and “discover” something that was already discovered a century ago. The freedom to make personal discoveries and mistakes and the knowledge you gain by doing so allows you to be much more creative than if you had just read about the end result in a journal.

So we have a paradox. I wrote this book to help you learn the meteorological advances made by others, but I discourage you from studying the works of others. As a scientist or engineer, you must make your own decision about the best balance of these two philosophies that will guide your future work.

Science Graffito

“If I have been able to see further than others, it was because I stood on the shoulders of giants.”
– Sir Isaac Newton.

HORIZONTAL FORCES

To solve the equations of motion for horizontal winds in an Eulerian framework, we need to know the horizontal forces acting on the air. The net “force per unit mass” consists of contributions from **advection (AD)**, **pressure-gradient force (PG)**, **Coriolis force (CF)**, and **turbulent drag (TD)**. In addition, imbalances between forces sometimes balance **centrifugal force (CN)**:

$$\frac{F_{xnet}}{m} = \frac{F_{xAD}}{m} + \frac{F_{xPG}}{m} + \frac{F_{xCN}}{m} + \frac{F_{xCF}}{m} \quad (10.7a)$$

$$\frac{F_{ynet}}{m} = \frac{F_{yAD}}{m} + \frac{F_{yPG}}{m} + \frac{F_{yCN}}{m} + \frac{F_{yCF}}{m} \quad (10.7b)$$

Units of force per mass are N/kg, which is identical to units of $m \cdot s^{-2}$ (see Appendix A). We will use these latter units.

Advection

Not only can wind blow air of different temperature or humidity into a region, but it can also blow air of different **specific momentum** (i.e., momentum per unit mass). Recall that momentum is defined as mass times velocity, hence specific momentum equals the velocity (i.e., the wind) by definition. Thus, the wind can blow different winds into a region. Namely, winds can change due to advection, in an Eulerian framework.

This is illustrated in Fig. 10.4a. Consider a mass of air (grey box) with slow U wind (5 m/s) in the north and faster U wind (10 m/s) in the south. Thus, U decreases toward the north, giving $\Delta U/\Delta y = \text{negative}$. This whole air mass is advected toward the north over a fixed weather station “O” by a mean wind ($V = \text{positive}$). At the time sketched in Fig. 10.4b, a west wind of 5 m/s is measured at “O”. Later, at the time of Fig. 10.4c, the west wind has increased to 10 m/s at the weather station. The rate of increase of U at “O” is larger for faster advection (V), and is larger if $\Delta U/\Delta y$ is more negative.

Thus, $\Delta U/\Delta t = -V \cdot \Delta U/\Delta y$ for this example. The advection term on the RHS causes an acceleration of U wind on the LHS, and thus acts like a force per unit mass: $\Delta U/\Delta t = F_{xAD}/m = -V \cdot \Delta U/\Delta y$.

Advection is not usually considered a force in the traditional Lagrangian sense, but you must always include it when momentum budget equations are rewritten in Eulerian frameworks. You have seen similar advection terms in the Eulerian heat and moisture budget equations earlier in this book.

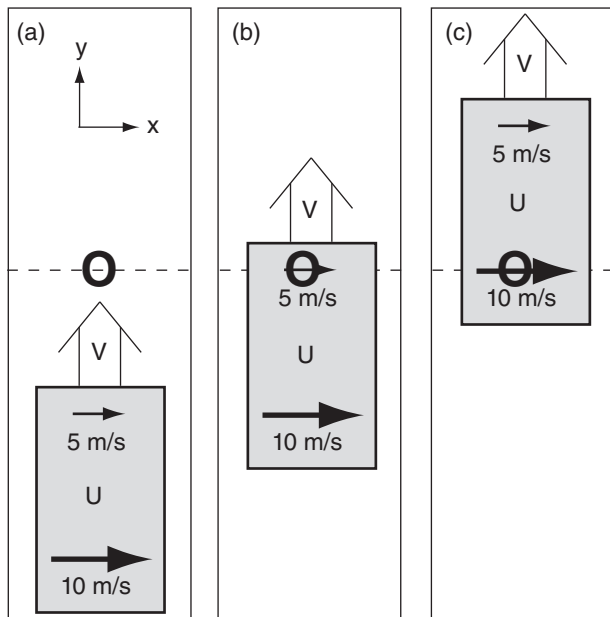

Figure 10.4
Illustration of V advection of U wind. “O” is a fixed weather station. Grey box is an air mass containing a gradient of U wind. Initial state (a) and later states (b and c).

In general, the components of advective force per unit mass are:

$$\frac{F_{xAD}}{m} = -U \cdot \frac{\Delta U}{\Delta x} - V \cdot \frac{\Delta U}{\Delta y} \quad \bullet(10.8a)$$

$$\frac{F_{yAD}}{m} = -U \cdot \frac{\Delta V}{\Delta x} - V \cdot \frac{\Delta V}{\Delta y} \quad \bullet(10.8b)$$

where $\Delta U/\Delta x$ is the gradient of U -wind in the x -direction, and the other gradients are defined similarly. Advection needs a **gradient** (i.e., change across a distance). Without a change of wind with distance, momentum advection cannot cause accelerations

Vertical advection of horizontal wind ($-W \cdot \Delta U/\Delta z$ in eq. 10.8a, and $-W \cdot \Delta V/\Delta z$ in eq. 10.8b) also exists. But W is often very small outside of thunderstorms, so we neglect vertical advection here.

Pressure-Gradient Force

Pressure-gradient force always acts perpendicularly to the isobars (or height contours) on a weather map, from high to low pressure (or heights). This force exists regardless of the wind speed, and does not depend on the wind speed. It starts the horizontal winds and can accelerate, decelerate, or change the direction of existing winds. On a weather map, more closely spaced isobars (i.e., more closely packed, with smaller distance Δd between them) indicate a greater pressure-gradient force (Fig. 10.5).

The components of pressure-gradient force are:

$$\frac{F_{xPG}}{m} = -\frac{1}{\rho} \cdot \frac{\Delta P}{\Delta x} \quad \bullet(10.9a)$$

$$\frac{F_{yPG}}{m} = -\frac{1}{\rho} \cdot \frac{\Delta P}{\Delta y} \quad \bullet(10.9b)$$

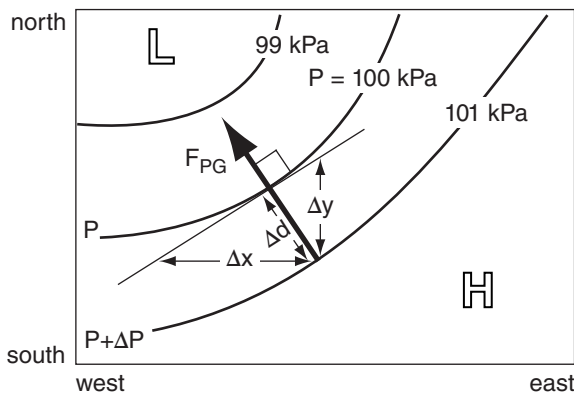

Figure 10.5
Pressure gradient force (heavy line) is perpendicular to isobars (medium lines) from high to low pressure. H and L indicate regions of high and low pressure, respectively.

Solved Example

Vancouver (British Columbia, Canada) is roughly 250 km north of Seattle (Washington, USA). The winds (U, V) are (8, 3) m/s in Vancouver and (5, 5) m/s in Seattle. Find the advective force per unit mass.

Solution

Given: (U, V) = (8, 3) m/s in Vancouver,
(U, V) = (5, 5) m/s in Seattle

$\Delta y = 250$ km, $\Delta x =$ not relevant (unknown)

Find: $F_{xAD}/m = ? \text{ m}\cdot\text{s}^{-2}$, $F_{yAD}/m = ? \text{ m}\cdot\text{s}^{-2}$

Use the definition of a gradient:

$$\Delta U/\Delta y = (8 - 5 \text{ m/s})/250,000 \text{ m} = 1.2 \times 10^{-5} \text{ s}^{-1}$$

$$\Delta U/\Delta x = 0 \text{ (unknown in this problem)}$$

$$\Delta V/\Delta y = (3 - 5 \text{ m/s})/250,000 \text{ m} = -0.8 \times 10^{-5} \text{ s}^{-1}$$

$$\Delta V/\Delta x = 0 \text{ (unknown)}$$

Average $U = (8 + 5 \text{ m/s})/2 = 6.5 \text{ m/s}$

Average $V = (3 + 5 \text{ m/s})/2 = 4 \text{ m/s}$

Use eq. (10.8a):

$$F_{xAD}/m = -(6.5 \text{ m/s}) \cdot 0 - (4 \text{ m/s}) \cdot (1.2 \times 10^{-5} \text{ s}^{-1})$$

$$= -4.8 \times 10^{-5} \text{ m}\cdot\text{s}^{-2}$$

Use eq. (10.8b):

$$F_{yAD}/m = -(6.5 \text{ m/s}) \cdot 0 - (4 \text{ m/s}) \cdot (-0.8 \times 10^{-5} \text{ s}^{-1})$$

$$= 3.2 \times 10^{-5} \text{ m}\cdot\text{s}^{-2}$$

Check: Units OK. Physics OK.

Discussion: The U winds are slower in Seattle than Vancouver, but are being blown toward Vancouver by the southerly flow. Thus, advection is decreasing the U -wind, hence, the negative sign. The V -wind is faster in Seattle, and these faster winds are being blown toward Vancouver, causing a positive acceleration there.

Solved Example

Milwaukee is 100 km east of Madison, Wisconsin, USA. The sea-level pressure at Milwaukee is 100.1 kPa and at Madison is 100 kPa. What is the pressure gradient force per mass? Assume $\rho = 1.2 \text{ kg}\cdot\text{m}^{-3}$.

Solution

Define: Cartesian coord. with $x = 0$ at Madison.

Given: $P = 100.1$ kPa at $x = 100$ km,

$P = 100.0$ kPa at $x = 0$ km. $\rho = 1.2 \text{ kg}\cdot\text{m}^{-3}$.

Find: $F_{xPG}/m = ? \text{ m}\cdot\text{s}^{-2}$

Use eq. (10.9a):

$$\frac{F_{xPG}}{m} = -\frac{1}{(1.2 \text{ kg}\cdot\text{m}^{-3})} \cdot \frac{(101,000 - 100,000) \text{ Pa}}{(400,000 - 0) \text{ m}}$$

$$= -8.33 \times 10^{-4} \text{ m}\cdot\text{s}^{-2}$$

where $1 \text{ Pa} = 1 \text{ kg}\cdot\text{m}^{-1}\cdot\text{s}^{-2}$ was used (Appendix A).

Check: Units OK. Physics OK.

Discussion: The negative answer implies that the force is in the negative x -direction; that is, from Milwaukee toward Madison.

Solved Example

If the height of the 50 kPa pressure surface decreases by 10 m northward across a distance of 500 km, what is the pressure-gradient force?

Solution

Given: $\Delta z = -10 \text{ m}$, $\Delta y = 500 \text{ km}$, $|g| = 9.8 \text{ m}\cdot\text{s}^{-2}$.
Find: $F_{PG}/m = ? \text{ m}\cdot\text{s}^{-2}$

Use eqs. (10.11a & b):

$F_{xPG}/m = 0 \text{ m}\cdot\text{s}^{-2}$, because $\Delta z/\Delta x = 0$. Thus, $F_{PG}/m = F_{yPG}/m$.

$$\frac{F_{yPG}}{m} = -|g| \cdot \frac{\Delta z}{\Delta y} = -\left(9.8 \frac{\text{m}}{\text{s}^2}\right) \cdot \left(\frac{-10\text{m}}{500,000\text{m}}\right)$$

$$F_{PG}/m = \underline{0.000196 \text{ m}\cdot\text{s}^{-2}}$$

Check: Units OK. Physics OK. Sign OK.

Discussion: For our example here, height decreases toward the north, thus a hypothetical ball would roll downhill toward the north. A northward force is in the positive y direction, which explains the positive sign of the answer.

Table 10-2. Sign s for centrifugal-force equations.

Hemisphere	For flow around a	
	Low	High
Northern	+1	-1
Southern	-1	+1

Solved Example

On the back side of a low pressure center in the northern hemisphere, winds are from the north at 10 m/s at distance 250 km from the low center. Find the centrifugal force.

Solution

Given: $R = 2.5 \times 10^5 \text{ m}$,
 $V = -10 \text{ m/s}$
Find: $F_{xCN}/m = ? \text{ m}\cdot\text{s}^{-2}$.

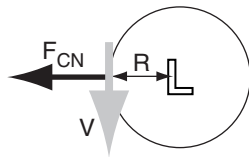

Use eq. (10.13a), with $s = +1$ from Table 10-2.

$$\frac{F_{xCN}}{m} = -1 \cdot \frac{(-5\text{m/s}) \cdot (5\text{m/s})}{5 \times 10^5} = \underline{-4 \times 10^{-4} \text{ m}\cdot\text{s}^{-2}}$$

Check: Units OK. Physics OK. Sketch OK.

Discussion: The negative sign indicates a force toward the west, which is indeed outward from the center of the circle.

where ρ is air density, and ΔP is the change of pressure across distance Δx or Δy . The negative sign makes the force act from high toward low pressure.

The magnitude of pressure-gradient force is

$$\left| \frac{F_{PG}}{m} \right| = \left| \frac{1}{\rho} \cdot \frac{\Delta P}{\Delta d} \right| \tag{10.10}$$

where Δd is the distance between isobars.

The hydrostatic equation (1.25) can be used to convert the pressure-gradient terms from height to pressure coordinates. On isobaric surfaces, the pressure-gradient terms become:

$$\frac{F_{xPG}}{m} = -|g| \cdot \frac{\Delta z}{\Delta x} \tag{10.11a}$$

$$\frac{F_{yPG}}{m} = -|g| \cdot \frac{\Delta z}{\Delta y} \tag{10.11b}$$

where $\Delta z/\Delta x$ and $\Delta z/\Delta y$ are the slopes of the isobaric surfaces (i.e., change of height with distance), and $|g| = 9.8 \text{ m}\cdot\text{s}^{-2}$ is the magnitude of gravitational acceleration. If you could place a hypothetical ball on the isobaric surface plotted in Fig. 10.2b, the direction that it would roll downhill is the direction of the pressure-gradient force, and the magnitude is

$$\left| \frac{F_{PG}}{m} \right| = \left| g \cdot \frac{\Delta z}{\Delta d} \right| \tag{10.12}$$

where Δd is distance between height contours.

Pressure-gradient force is the ONLY force that can drive the horizontal winds in the atmosphere. The other forces, such as Coriolis, drag, centrifugal, and even advection, disappear for zero wind speed. Hence, these other forces can change the direction and speed of an existing wind, but they cannot create a wind out of calm conditions.

Centrifugal Force

Newton's laws of motion state that an object tends to move in a straight line unless acted upon by a force in a different direction. Such a force, called centripetal force, causes the object to change direction and bend its trajectory. **Centripetal** force is the sum or the imbalance of other forces.

Centrifugal force is an apparent force that is opposite to centripetal force and pulls outward from the center of the turn. The components of centrifugal force are

$$\frac{F_{xCN}}{m} = +s \cdot \frac{V \cdot M}{R} \tag{10.13a}$$

$$\frac{F_{yCN}}{m} = -s \cdot \frac{U \cdot M}{R} \tag{10.13b}$$

where s is a sign coefficient given in Table 10-2, $M = (U^2 + V^2)^{1/2}$ is wind speed (always positive), and R is the radius of curvature. The sign depends on whether air is circulating around a high or low pressure center, and whether it is in the Northern or Southern Hemisphere.

The total magnitude is:

$$\left| \frac{F_{CN}}{m} \right| = \frac{M^2}{R} \quad (10.14)$$

Coriolis Force

Coriolis force is an apparent force caused by the rotation of the Earth. It acts perpendicular to the wind direction, to the right in the N. Hemisphere, and to the left in the Southern (Fig. 10.6).

To understand Coriolis force, we need to quantify the rotation rate of the Earth. The Earth rotates one full revolution (2π radians) during a sidereal day (i.e., relative to the fixed stars, $P_{sidereal}$ is a bit less than 24 h, see Appendix B), giving an angular rotation rate of

$$\begin{aligned} \Omega &= 2 \cdot \pi / P_{sidereal} && \bullet(10.15) \\ &= 0.729\,211\,6 \times 10^{-4} \text{ radians/s} \end{aligned}$$

The units for Ω are often abbreviated as s^{-1} . Using this rotation rate, a **Coriolis parameter** is defined as

$$f_c = 2 \cdot \Omega \cdot \sin(\phi) \quad \bullet(10.16)$$

where $2 \cdot \Omega = 1.458423 \times 10^{-4} \text{ s}^{-1}$, and ϕ is latitude. This parameter is constant at any fixed location. At mid-latitudes, the magnitude is on the order of $f_c = 1 \times 10^{-4} \text{ s}^{-1}$.

In the N. Hemisphere, the Coriolis force is:

$$\frac{F_{xCF}}{m} = f_c \cdot V \quad \bullet(10.17a)$$

$$\frac{F_{yCF}}{m} = -f_c \cdot U \quad \bullet(10.17b)$$

Thus, there is no Coriolis force when there is no wind. Coriolis force cannot cause the wind to blow; it can only change its direction.

The magnitude of Coriolis force is:

$$|F_{CF} / m| \approx 2 \cdot \Omega \cdot |\sin(\phi) \cdot M| \quad (10.18a)$$

or

$$|F_{CF} / m| \approx |f_c \cdot M| \quad (10.18b)$$

as is shown in the 2nd Focus box on Coriolis force.

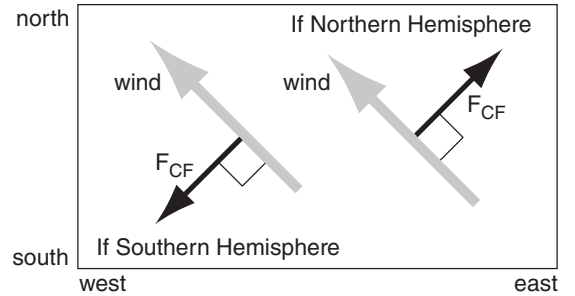

Figure 10.6
Coriolis force (dark lines).

Solved Example

a) Plot Coriolis parameter vs. latitude. b) Find Coriolis force at Norman, OK, USA, for a wind of $U = 10 \text{ m/s}$.

Solution

Given: $U = 10 \text{ m/s}$, $\phi = 35.2^\circ \text{N}$ at Norman.

Find: Plot f_c vs ϕ . Also: $F_{yCF}/m = ? \text{ m}\cdot\text{s}^{-2}$.

a) Find f_c (s^{-1}) vs. ϕ ($^\circ$) using eq. (10.16). For example:
 $f_c = (1.458 \times 10^{-4} \text{ s}^{-1}) \cdot \sin(35.2^\circ) = 8.4 \times 10^{-5} \text{ s}^{-1}$.

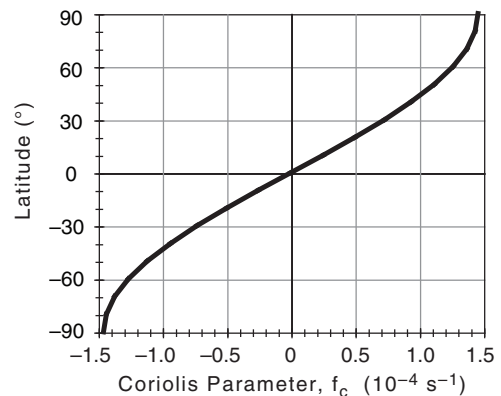

b) Coriolis force in the y -direction (eq. 10.17b) is:
 $F_{yCF}/m = -(8.4 \times 10^{-5} \text{ s}^{-1}) \cdot (10 \text{ m/s}) = -8.4 \times 10^{-4} \text{ m}\cdot\text{s}^{-2}$.

Check: Units OK. Physics OK.

Discussion: The $-$ sign means force is north to south.

FOCUS • Coriolis Force in 3-D

Eqs. (10.17) give only the dominant components of Coriolis force. There are other smaller-magnitude Coriolis terms (labeled *small* below) that are usually neglected. The full Coriolis force in 3-dimensions is:

$$\frac{F_{xCF}}{m} = f_c \cdot V - 2\Omega \cdot \cos(\phi) \cdot W \quad (10.17c)$$

[small because often $W \ll V$]

$$\frac{F_{yCF}}{m} = -f_c \cdot U \quad (10.17d)$$

$$\frac{F_{zCF}}{m} = 2\Omega \cdot \cos(\phi) \cdot U \quad (10.17e)$$

[small relative to other vertical forces]

FOCUS • What is Coriolis Force?

In 1835, Gaspar Gustave Coriolis used kinetic-energy conservation to explain the apparent force that now bears his name. The following clarification was provided by Anders Persson in 1998 and 2006.

Background

Coriolis force can be interpreted as the difference between two other forces: centrifugal force and gravitational force.

As discussed previously, **centrifugal force** is $F_{CN}/m = (M_{tan})^2/R$, where M_{tan} is the tangential velocity of an object moving along a curved path with radius of curvature R (see Fig. 10.a). This force increases if the object moves faster, or if the radius becomes smaller. The symbol X marks the center of rotation of the object, and the small black circle indicates the object.

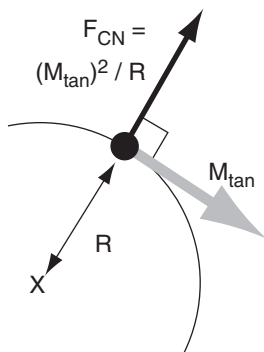

Figure 10.a. Centrifugal force, F_{CN} .

Because the Earth is plastic (i.e., deformable), centrifugal force due to the Earth's rotation and **gravitational force** F_G have shaped the surface into an ellipsoid, not a sphere. This is exaggerated in Fig. 10.b. The vector sum of F_G and F_{CN} is the **effective gravity**, F_{EG} . This effective gravity acts perpendicular to the local surface, and defines the direction we call **down**. Thus, a stationary object feels no net force (the downward force is balanced by the Earth holding it up).

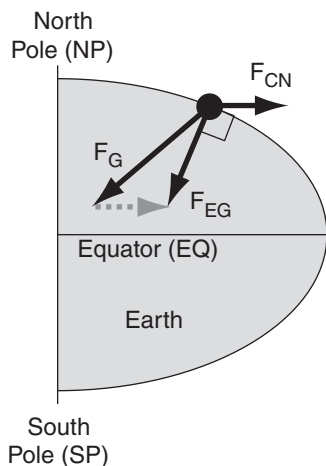

Figure 10.b. North-south slice through Earth.

(continues in next column)

FOCUS • Coriolis Force (continuation)

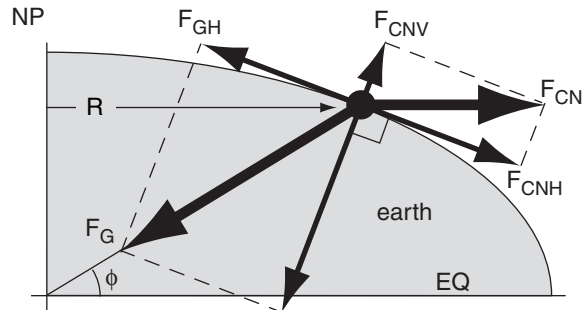

Figure 10.c. Forces. F_{GV}

Now that “up” and “down” are identified, we can split centrifugal and actual gravitational forces into local horizontal (subscript H) and vertical (subscript V) components (Fig. 10.c). Because F_{CN} is always parallel to the equator (EQ), trigonometry gives $F_{CNH} \approx F_{CN} \cdot \sin(\phi)$, where ϕ is latitude.

Objects at Rest

The Earth rotates counterclockwise when viewed from above the north pole (NP). During time interval Δt , any single meridian (a longitude line, such as labeled with distance R in Fig. 10.d) will rotate by angle $\Omega \Delta t$, where Ω is the angular velocity of Earth ($= 360^\circ/\text{sidereal day}$).

Suppose an object (the dark circle) is at rest on this meridian. Then during the same time interval Δt , it will move as shown by the grey arrow, at speed $M_{tan} = \Omega \cdot R$. Because this movement follows a parallel (latitude line), and parallels encircle the Earth's axis, the stationary object is turning around a circle. This creates centrifugal force. The horizontal component F_{CNH} balances F_{GH} , giving zero net apparent horizontal force on the object (Fig. 10.d).

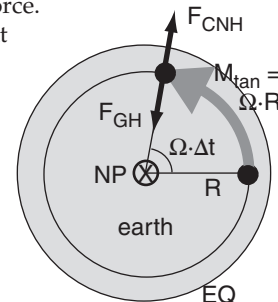

Figure 10.d. Object at rest.

Objects Moving East or West

Next, we can ask what happens if the object moves eastward with velocity M relative to the Earth's surface (shown by the thin white arrow in Fig. 10.e). The Earth is rotating as before, as indicated by the thin meridian lines in the figure. Thus, the total movement of the object is faster than before, as shown by the grey arrow. This implies greater total centrifugal force, which results in a greater horizontal component F_{CNH} . However, the gravity component F_{GH} is unchanged.

(continues in next column)

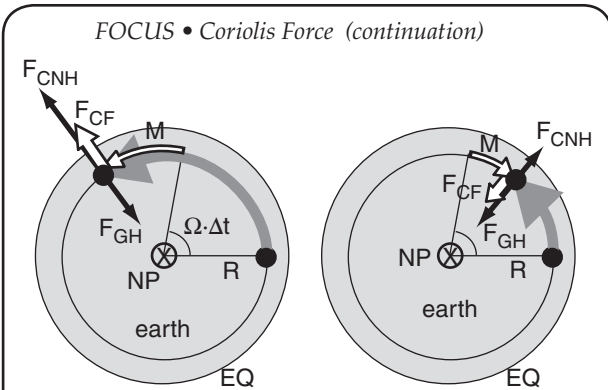

Figure 10.e.
Object moving east.

Figure 10.f.
Object moving west.

Thus, those two forces (F_{CNH} & F_{GH}) do NOT balance. The difference between them is a net force to the right of the relative motion M . This force difference is called **Coriolis force**, F_{CF} , and is indicated by the thick white arrow in Fig. 10.e.

Similarly, for an object moving westward (thin white arrow in Fig. 10.f), the net tangential velocity (grey arrow) is slower, giving an imbalance between F_{CNH} & F_{GH} that acts to the right of M . This is identified as Coriolis force, as shown with the thick white arrow.

Objects Moving North or South

For a northward moving object, the rotation of the Earth (dashed thick grey line) and the relative motion of the object (M , thin white arrow) combine to cause a path shown with the solid thick grey line (Fig. 10.g). This has a smaller radius of curvature (R) about a center of rotation (X) that is NOT on the North Pole (O). The smaller radius causes a greater horizontal component of centrifugal force (F_{CNH}), which points outward from X .

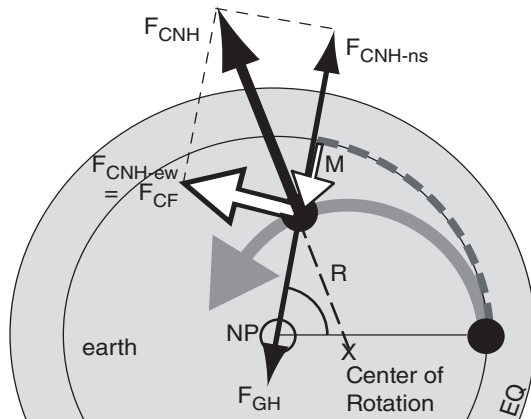

Figure 10.g. Object moving north.

We can conceptually divide this horizontal centrifugal force into a north-south component (F_{CNH-ns}) and an east-west component (F_{CNH-ew}). The southward component F_{CNH-ns} balances the horizontal
(continues in next column)

gravitational component F_{GH} , which hasn't changed very much relative to the other changes. However, the east-west component is acting to the right of the relative object motion M , and is identified as Coriolis force: $F_{CF} = F_{CNH-ew}$

Similarly, a southward moving object has a larger radius of curvature, giving a Coriolis force to the right. In fact, an object moving in any arbitrary direction has Coriolis force acting to the right in the Northern Hemisphere.

Magnitude of Coriolis Force

For an object at rest (Figs. 10.c & d):

$$F_{GH} = F_{CNH} \equiv F_{CNHR} \tag{C1}$$

where subscript R denotes "rest". At rest:

$$M_{tan\ rest} = \Omega \cdot R \tag{C2}$$

For an eastward moving object (Fig. 10.e), Coriolis force is defined as:

$$\begin{aligned} F_{CF} &\equiv F_{CNH} - F_{GH} && \text{(definition)} \\ &= F_{CNH} - F_{CNHR} && \text{(from eq. C1)} \\ &= \sin(\phi) \cdot [F_{CN} - F_{CNR}] && \text{(from Fig. 10.c)} \end{aligned}$$

Divide by mass m , and plug in the definition for centrifugal force as velocity squared divided by radius:

$$F_{CF} / m = \sin(\phi) \cdot [(M_{tan})^2 / R - (M_{tan\ rest})^2 / R]$$

Use $M_{tan} = M_{tan\ rest} + M$, along with eq. (C2):

$$\begin{aligned} F_{CF} / m &= \sin(\phi) \cdot [(\Omega \cdot R + M)^2 / R - (\Omega \cdot R)^2 / R] \\ &= \sin(\phi) \cdot [2 \cdot \Omega \cdot M + (M^2 / R)] \end{aligned}$$

The last term is small & can be neglected compared to the first term. Thus, the magnitude of Coriolis force is:

$$\begin{aligned} F_{CF} / m &\approx 2 \cdot \Omega \cdot \sin(\phi) \cdot M && \text{(10.18)} \\ &\equiv f_c \cdot M && \text{(from eq. 10.16)} \end{aligned}$$

This answer is found for motion in any direction.

BEYOND ALGEBRA • Apparent Forces

In vector form, centrifugal force/mass for an object at rest on Earth is $-\Omega \times (\Omega \times \mathbf{r})$, and Coriolis force/mass is $-2\Omega \times \mathbf{V}$, where vector Ω points along the Earth's axis toward the north pole, \mathbf{r} points from the Earth's center to the object, \mathbf{V} is the object's velocity relative to Earth, and \times is the vector cross product.

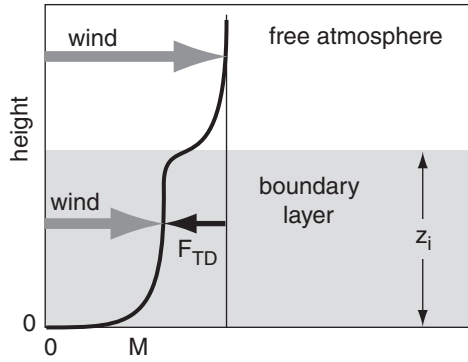

Figure 10.7

Turbulent drag force F_{TD} opposes the wind in the boundary layer.

Solved Example

Find the drag force per unit mass on a wind of $U = 10$ m/s, $V = 0$ for a: (a) statically neutral boundary layer over smooth ground; and (b) statically unstable boundary layer with $w_B = 45$ m/s. The boundary layer is 1 km thick.

Solution

Given: $U = M = 10$ m/s, $z_i = 1000$ m,

$$C_D = 2 \times 10^{-3}, \quad w_B = 45 \text{ m/s.}$$

Find: $F_{xTD}/m = ? \text{ m}\cdot\text{s}^{-2}$.

(a) Combine eqs. (10.21) and (10.19a):

$$\begin{aligned} \frac{F_{xTD}}{m} &= -C_D \cdot M \cdot \frac{U}{z_i} = -(0.02) \cdot \frac{(15 \text{ m/s})^2}{1500 \text{ m}} \\ &= \underline{-2 \times 10^{-4} \text{ m}\cdot\text{s}^{-2}}. \end{aligned}$$

(b) Combine eqs. (10.22) and (10.19a):

$$\begin{aligned} \frac{F_{xTD}}{m} &= -b_D \cdot w_B \cdot \frac{U}{z_i} \\ &= -(0.00183) \cdot (50 \text{ m/s}) \cdot \frac{(15 \text{ m/s})}{1500 \text{ m}} \\ &= \underline{-8.24 \times 10^{-4} \text{ m}\cdot\text{s}^{-2}}. \end{aligned}$$

Check: Units OK. Physics OK.

Discussion: The negative sign means that the drag force is toward the west, which is opposite the wind direction. Both mechanical and buoyant turbulence are equally effective at transporting frictional information to the air.

Turbulent-Drag Force

At the Earth's surface the air experiences drag against the ground. This turbulent-drag force increases with wind speed, and is always in a direction opposite to the wind direction. Namely, drag slows the wind (Fig. 10.7).

Only the **boundary layer** (see the Atmospheric Boundary Layer chapter) experiences this drag. It is not felt by the air in the remainder of the troposphere (except for deep vigorous thunderstorms or for mountain-wave drag, see the Local Winds chapter). The drag force acting on a boundary layer of depth z_i is:

$$\frac{F_{xTD}}{m} = -w_T \cdot \frac{U}{z_i} \quad \bullet(10.19a)$$

$$\frac{F_{yTD}}{m} = -w_T \cdot \frac{V}{z_i} \quad \bullet(10.19b)$$

where w_T is a turbulent **transport velocity**.

The total magnitude of turbulent drag force is

$$\left| \frac{F_{TD}}{m} \right| = w_T \cdot \frac{M}{z_i} \quad (10.20)$$

and is opposite to the wind direction.

During windy conditions of near **neutral** static stability, turbulence is generated primarily by the **wind shear** (change of wind speed or direction with height). This turbulence transports frictional information upward from the ground to the air at rate:

$$w_T = C_D \cdot M \quad (10.21)$$

where wind speed M is always positive, and C_D is a dimensionless **drag coefficient** in the range of 2×10^{-3} over smooth surfaces to 2×10^{-2} over rough or forested surfaces (see the Atmospheric Boundary Layer chapter). It is similar to the bulk heat transfer coefficient that was discussed in the Heat chapter.

During statically **unstable** conditions of light winds and strong surface heating (e.g., daytime), buoyant thermals transport the frictional information upward at rate:

$$w_T = b_D \cdot w_B \quad (10.22)$$

where w_B is the **buoyancy velocity scale** (always positive, see the Heat chapter), and $b_D = 1.83 \times 10^{-3}$ is dimensionless.

Summary of Forces

Item	Name of Force	Direction	Magnitude (N/kg)	Horiz. (H) or Vert. (V)	Remarks ("item" is in column 1; H & V in col. 5)
1	gravity	down	$\left \frac{F_G}{m} \right = g = 9.8 \text{ m}\cdot\text{s}^{-2}$	V	hydrostatic equilibrium when items 1 & 2V balance
2	pressure gradient	from high to low pressure	$\left \frac{F_{PG}}{m} \right = \left \frac{1}{\rho} \cdot \frac{\Delta P}{\Delta d} \right $	V & H	the only force that can drive horizontal winds
3	Coriolis (apparent)	90° to right (left) of wind in Northern (Southern) Hemisphere	$\left \frac{F_{CF}}{m} \right = 2 \cdot \Omega \cdot \sin(\phi) \cdot M$	H*	geostrophic wind when 2H and 3 balance (explained later in horiz. wind section)
4	turbulent drag	opposite to wind	$\left \frac{F_{TD}}{m} \right = w_T \cdot \frac{M}{z_i}$	H*	boundary-layer wind when 2H, 3 and 4 balance (explained in horiz. wind section)
5	centrifugal (apparent)	away from center of curvature	$\left \frac{F_{CN}}{m} \right = \frac{M^2}{R}$	H*	centripetal = opposite of centrifugal. Gradient wind when 2H, 3 and 5 balance
6	advection (apparent)	(any)	$\left \frac{F_{AD}}{m} \right = M \cdot \left \frac{\Delta(U \text{ or } V)}{\Delta d} \right $	V & H	neither creates nor destroys momentum; just moves it

*Horizontal is the direction we will focus on. However, Coriolis force has a small vertical component for zonal winds. Turbulent drag can exist in the vertical for rising or sinking air, but has completely different form than the boundary-layer drag given above. Centrifugal force can exist in the vertical for vortices with horizontal axes. Note: units N/kg = m·s⁻².

EQUATIONS OF HORIZONTAL MOTION

Combining the forces from eqs. (10.7, 10.8, 10.9, 10.17, and 10.19) into Newton's Second Law of Motion (eq. 10.5) gives simplified equations of horizontal motion:

•(10.23a)

$$\frac{\Delta U}{\Delta t} = -U \frac{\Delta U}{\Delta x} - V \frac{\Delta U}{\Delta y} - \frac{1}{\rho} \cdot \frac{\Delta P}{\Delta x} + f_c \cdot V - w_T \cdot \frac{U}{z_i}$$

•(10.23b)

$$\frac{\Delta V}{\Delta t} = -U \frac{\Delta V}{\Delta x} - V \frac{\Delta V}{\Delta y} - \frac{1}{\rho} \cdot \frac{\Delta P}{\Delta y} - f_c \cdot U - w_T \cdot \frac{V}{z_i}$$

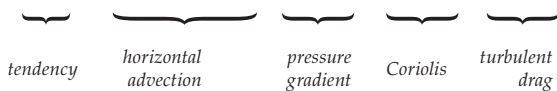

These are the forecast equations for wind. Centrifugal force is not included because it is the opposite of **centripetal** force, which is the net imbalance of the other forces already included above.

As was shown in the solved examples, each of the terms can be of similar magnitude: 1x10⁻⁴ to

10x10⁻⁴ m·s⁻² (which is equivalent units of N/kg, see Appendix A for review). For some situations, some of the terms are small enough to be neglected compared to the others. For example, above the boundary layer the turbulent-drag term is near zero. Near the equator, Coriolis force is near zero. At the center of high or low pressure regions, the pressure gradient is near zero.

There are other physical processes that have been neglected in the simplified equations just presented. **Molecular friction** is significant in the bottom few millimeters of the ground. **Mountain-wave drag** can be large in mountainous regions (see the Local Winds chapter). Cumulus clouds can cause turbulent **convective mixing** above the boundary layer (see the Atmospheric Boundary Layer and Thunderstorm chapters). Vertical advection of the horizontal wind has been neglected because it often is small. Mean vertical motions (e.g., large-scale subsidence) will be examined later in this chapter.

In the section that follows, the equations of motion are simplified for some special cases, to yield theoretical winds in the horizontal. Where appropriate, the forces and winds will also be given in isobaric coordinates.

Table 10-4. Names of idealized steady-state horizontal winds, and the forces that govern them.

$0 = -U \frac{\Delta U}{\Delta x} - \frac{1}{\rho} \cdot \frac{\Delta P}{\Delta x} + f_c \cdot V - w_T \cdot \frac{U}{z_i} + s \frac{V \cdot M}{R}$				
Forces:	pressure gradient	Coriolis	turbulent drag	centrifugal
Wind Name				
Geostrophic	•	•		
Gradient	•	•		•
Boundary Layer	•	•	•	
BL Gradient	•	•	•	•
Cyclostrophic	•			•
Inertial		•		•
Antitriptic	•		•	

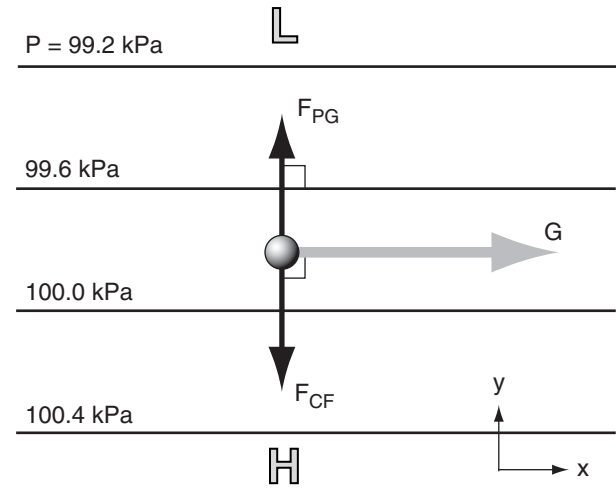

Figure 10.8 Idealized weather map, showing geostrophic wind (G , grey arrow) caused by a balance between two forces (black arrows): pressure-gradient force (F_{PG}) and Coriolis force (F_{CF}). P is pressure, with isobars plotted as thin black lines. L and H are low and high-pressure regions. The small sphere represents an air parcel.

Solved Example
 Pressure increases 1 kPa eastward across a distance of 500 km. What is the geostrophic wind speed, given $\rho = 1 \text{ kg/m}^3$ and $f_c = 10^{-4} \text{ s}^{-1}$?

Solution
 Given: $\Delta P = 1 \text{ kPa}$, $\Delta x = 500 \text{ km}$, $\rho = 1 \text{ kg/m}^3$, $f_c = 10^{-4} \text{ s}^{-1}$.
 Find: $G = ? \text{ m/s}$

$U_g = 0$, thus $G = V_g$. Use eq. (10.26b):

$$U_g = \frac{-1}{(1.2 \text{ kg/m}^3) \cdot (1.1 \times 10^{-4} \text{ s}^{-1})} \cdot \frac{(-21)}{(800)} = \mathbf{20 \text{ m/s}}$$

Check: Units OK. Physics OK.
Discussion: “Kilo” in the numerator & denominator cancel. Given that $\Delta P/\Delta x = 0.002 \text{ kPa/km}$, the answer agrees with Fig. 10.10. The wind is toward the north.

HORIZONTAL WINDS

When air accelerates to create wind, forces such as Coriolis and drag change too, because they depend on the wind speed. This, in turn, changes the acceleration via eqs. (10.23), so there is a **feedback process**. This feedback continues until the forces finally balance each other. At that point, there is no net force, and no further acceleration.

This final condition is called **steady state**:

$$\frac{\Delta U}{\Delta t} = 0, \quad \frac{\Delta V}{\Delta t} = 0 \quad \bullet(10.24)$$

In steady-state, wind speeds do not change with time, but are not necessarily zero. Only the acceleration is zero.

Under certain idealized conditions, some of the forces in the equations of motion are small enough to be neglected. For these situations, theoretical steady-state winds can be found based on only the remaining larger-magnitude forces. These theoretical winds are given special names, as listed in Table 10-4. These winds are examined next in more detail. The real winds under these special conditions are often close to the theoretical winds.

Geostrophic Wind

The geostrophic wind (U_g, V_g) is a theoretical wind that results from a steady-state balance between pressure-gradient force and Coriolis force (Fig. 10.8). After setting the other forces to zero, eqs. (10.23) become:

$$0 = -\frac{1}{\rho} \cdot \frac{\Delta P}{\Delta x} + f_c \cdot V \quad (10.25a)$$

$$0 = -\frac{1}{\rho} \cdot \frac{\Delta P}{\Delta y} - f_c \cdot U \quad (10.25b)$$

Solving these equations for U and V , and then defining $U \equiv U_g$ and $V \equiv V_g$, gives:

$$U_g = -\frac{1}{\rho \cdot f_c} \cdot \frac{\Delta P}{\Delta y} \quad \bullet(10.26a)$$

$$V_g = +\frac{1}{\rho \cdot f_c} \cdot \frac{\Delta P}{\Delta x} \quad \bullet(10.26b)$$

where $f_c = (1.4584 \times 10^{-4} \text{ s}^{-1}) \cdot \sin(\text{latitude})$ is the Coriolis parameter, ρ is air density, and $\Delta P/\Delta x$ and $\Delta P/\Delta y$ are the horizontal pressure gradients.

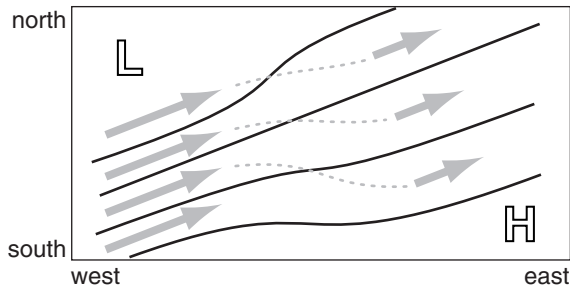

Figure 10.9
Geostrophic winds (grey arrows) are faster (longer arrows) where isobars (thin lines) are closer together. (For N. Hemis.)

In regions of straight isobars above the top of the boundary layer and away from the equator, the actual winds are approximately geostrophic. These winds blow parallel to the isobars or height contours, with low pressure to the left in the Northern Hemisphere (Fig. 10.9). The wind is faster in regions where the isobars are closer together (i.e., where the isobars are tightly packed) and at lower latitudes (Fig. 10.10).

The total geostrophic wind speed G is:

$$G = \sqrt{U_g^2 + V_g^2} \quad (10.27)$$

If Δd is the distance between two isobars (in the direction of greatest pressure change; namely, perpendicular to the isobars), then the magnitude of the geostrophic wind is:

$$G = \left| \frac{1}{\rho \cdot f_c} \cdot \frac{\Delta P}{\Delta d} \right| \quad \bullet(10.28)$$

Above sea level, weather maps are often on isobaric surfaces (constant pressure charts). The geostrophic wind as a function of horizontal distances between height (z) contours on a constant-pressure chart is:

$$U_g = -\frac{|g|}{f_c} \cdot \frac{\Delta z}{\Delta y} \quad \bullet(10.29a)$$

$$V_g = +\frac{|g|}{f_c} \cdot \frac{\Delta z}{\Delta x} \quad \bullet(10.29b)$$

where $|g| = 9.8 \text{ m}\cdot\text{s}^{-2}$ is gravitational acceleration magnitude, and f_c is the Coriolis parameter. The corresponding magnitude of geostrophic wind on an isobaric chart is:

$$G = \left| \frac{g}{f_c} \cdot \frac{\Delta z}{\Delta d} \right| \quad \bullet(10.29c)$$

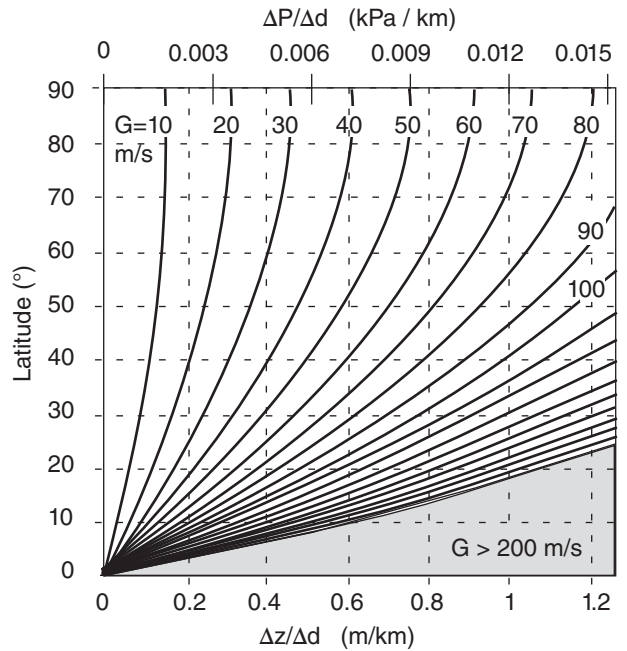

Figure 10.10
Geostrophic wind speed G vs. latitude and height gradient ($\Delta z/\Delta d$) on a constant pressure surface. Top scale is pressure gradient at sea level.

Solved Example

If height increases by 100 m eastward across a distance of 500 km, then what is the geostrophic wind speed, given $f_c = 10^{-4} \text{ s}^{-1}$?

Solution

Given: $\Delta z = 100 \text{ m}$, $\Delta x = 500 \text{ km}$, $f_c = 10^{-4} \text{ s}^{-1}$.

Find: $G = ? \text{ m/s}$

$U_g = 0$, thus $G = V_g$. Use eq. (10.29b):

$$V_g = +\frac{|g|}{f_c} \cdot \frac{\Delta z}{\Delta x} = \left(\frac{9.8 \text{ m}\cdot\text{s}^{-2}}{0.00009 \text{ s}^{-1}} \right) \cdot \left(\frac{50 \text{ m}}{200,000 \text{ m}} \right) = \mathbf{19.6 \text{ m/s}}$$

Check: Units OK. Physics OK.

Discussion: This is nearly the same answer as before. Δz of 100 m on an isobaric surface corresponds to ΔP of roughly 1 kPa on a constant height surface. A hypothetical ball rolling downhill would start moving toward the west, but would be deflected northward by Coriolis force in the Northern Hemisphere.

FOCUS • Approach to Geostrophy

How does an air parcel, starting from rest, approach the final steady-state geostrophic wind speed G sketched in Fig. 10.8?

Start with the equations of horizontal motion (10.23), and ignore all terms except the tendency, pressure-gradient force, and Coriolis force. Use the definition of

continues on next page

FOCUS • Appr. to Geostrophy *(continued)*

geostrophic wind (eqs. 10.26) to write the resulting simplified equations as:

$$\Delta U / \Delta t = -f_c \cdot (V_g - V)$$

$$\Delta V / \Delta t = f_c \cdot (U_g - U)$$

Next, rewrite these as forecast equations:

$$U_{new} = U_{old} - \Delta t \cdot f_c \cdot (V_g - V_{old})$$

$$V_{new} = V_{old} + \Delta t \cdot f_c \cdot (U_g - U_{new})$$

Start with initial conditions $(U_{old}, V_{old}) = (0, 0)$, and then iteratively solve the equations on a spreadsheet to forecast the wind.

For example, consider the conditions given in the previous solved example, where we would anticipate the wind should approach $(U_g, V_g) = (0, 20)$ m/s. The actual evolution of winds (U, V) and air parcel position (X, Y) are shown in Figs. below.

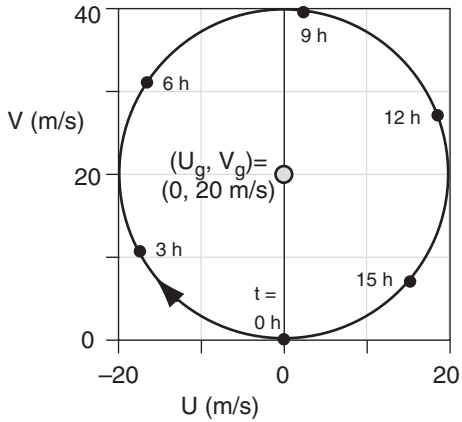

Surprisingly, the winds never reach geostrophic equilibrium, but instead rotate around the geostrophic wind. This is called an **inertial oscillation**, with period of $P = 2\pi/f_c$. Twice this period is called a **pendulum day**. For our solved example, $P = 17.45$ h.

The net result in the figure below is that the wind indeed moves at the geostrophic speed of 20 m/s to the north (≈ 1250 km in 17.45 h), but along the way it staggers west and east with an additional **ageostrophic** (non-geostrophic) part.

Inertial oscillations are sometimes observed at night in the boundary layer, but rarely higher in the atmosphere. Why not? (1) The ageostrophic component of wind (wind from the East in this example) moves air mass, and changes the pressure gradient. (2) Friction damps the oscillation toward a steady wind.

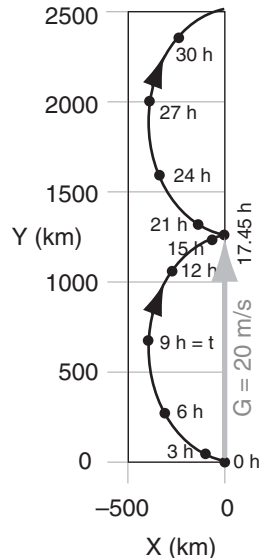

If the **geopotential** $\Phi = |g| \cdot z$ is substituted in eqs. (10.29), the resulting geostrophic winds are:

$$U_g = -\frac{1}{f_c} \cdot \frac{\Delta \Phi}{\Delta y} \tag{10.30a}$$

$$V_g = \frac{1}{f_c} \cdot \frac{\Delta \Phi}{\Delta x} \tag{10.30b}$$

Gradient Wind

Around a high or low pressure center, the steady-state wind follows the curved isobars, with low pressure to the left in the Northern Hemisphere. Around lows, the wind is slower than geostrophic, called **subgeostrophic**, regardless of the hemisphere. Around highs, the steady-state wind is faster than geostrophic, or **supergeostrophic**. The curved steady-state wind is called the **gradient wind**.

The gradient wind occurs because of an imbalance (Figs. 10.11 & 10.12) between pressure-gradient (F_{PG}) and Coriolis forces (F_{CF}); namely, the net force (F_{net}) is not zero. This net force is called centripetal force, and is what causes the wind to continually change direction as it goes around a circle. By describing this change in direction as causing an apparent force (centrifugal), we can find the steady-state gradient wind:

$$0 = -\frac{1}{\rho} \cdot \frac{\Delta P}{\Delta x} + f_c \cdot V + s \cdot \frac{V \cdot M}{R} \tag{10.31a}$$

$$0 = -\frac{1}{\rho} \cdot \frac{\Delta P}{\Delta y} - f_c \cdot U - s \cdot \frac{U \cdot M}{R} \tag{10.31b}$$

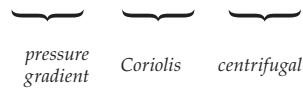

Because the gradient wind is for flow around a circle, we can frame the governing equations in radial coordinates:

$$\frac{1}{\rho} \cdot \frac{\Delta P}{\Delta R} = f_c \cdot M_{tan} + \frac{M_{tan}^2}{R} \tag{10.32}$$

where R is radial distance from the center of the circle, f_c is the Coriolis parameter, ρ is air density, $\Delta P/\Delta R$ is the radial pressure gradient, and M_{tan} is the magnitude of the tangential velocity; namely, the gradient wind. The signs of the terms in this equation are for flow around a low.

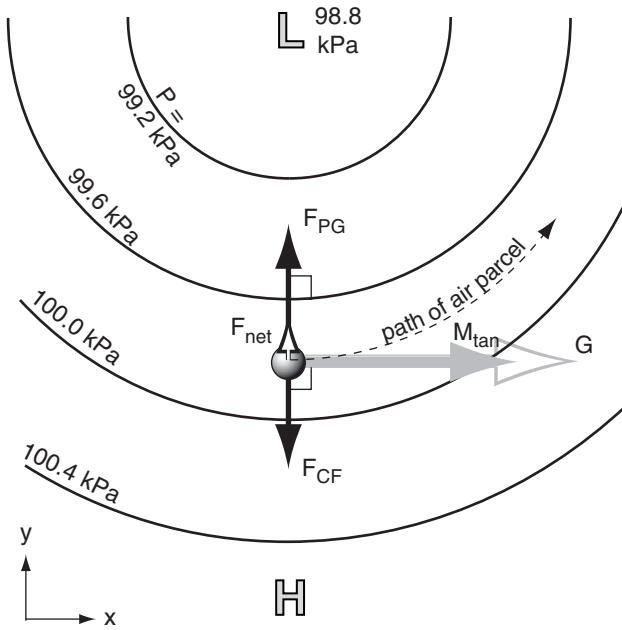

Figure 10.11
 Forces (dark arrows) that cause the gradient wind (solid grey arrow, M_{tan}) to be slower than geostrophic (hollow grey arrow) when circling around a low-pressure center (called a cyclone in the N. Hem.). The short white arrow with black outline shows centripetal force (the imbalance between the other two forces). Centripetal force pulls the air parcel (grey sphere) inward to force the wind direction to change as needed for the wind to turn along a circular path.

Define $U_{tan} \equiv U$ and $V_{tan} \equiv V$ as the components of gradient wind, with a total gradient wind speed of $M_{tan} = [U_{tan}^2 + V_{tan}^2]^{1/2}$. One solution to eq. (10.32) is

$$M_{tan} = G \pm \frac{M_{tan}^2}{f_c \cdot R} \quad (10.33)$$

where M_{tan} is the gradient-wind speed, and where the negative sign is used for flow around low pressure centers, and the positive sign for highs. This solution demonstrates that wind is “slow around lows” (Fig. 10.13), meaning slower than geostrophic G . However, the solution is implicit because the desired wind M_{tan} is on both sides of the equal sign.

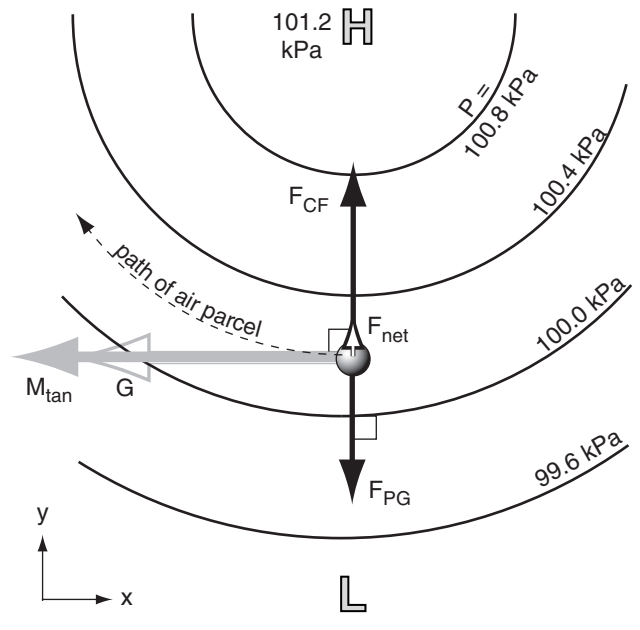

Figure 10.12
 Forces (dark arrows) that cause the gradient wind (solid grey arrow, M_{tan}) to be faster than geostrophic (hollow grey arrow) for an air parcel (grey sphere) circling around a high-pressure center (called an anticyclone in the N. Hemisphere).

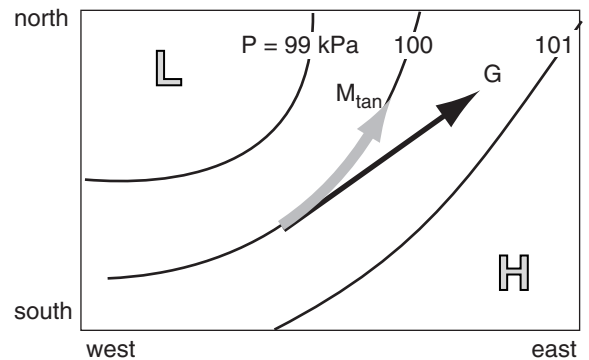

Figure 10.13
 Geostrophic wind G and gradient wind M_{tan} around a low pressure center in the Northern Hemisphere.

Solved Example

What radius of curvature causes the gradient wind to equal the geostrophic wind?

Solution

Given: $M_{tan} = G$ Find: $R = ?$ km

Use eq. (10.33), with $M_{tan} = G$: $G = G \pm G^2/(f_c \cdot R)$

This is a valid equality $G = G$ only when the last term in eq. (10.33) approaches zero; i.e., in the limit of $R = \infty$.

Check: Eq. (10.33) still balances in this limit. **Discussion:** Infinite radius of curvature is a straight line, which (in the absence of any other forces such as turbulent drag) is the condition for geostrophic wind.

Solved Example

If the geostrophic wind around a low is 10 m/s, then what is the gradient wind speed, given $f_c = 10^{-4} \text{ s}^{-1}$ and a radius of curvature of 500 km? Also, what is the curvature Rossby number?

Solution

Given: $G = 10 \text{ m/s}$, $R = 500 \text{ km}$, $f_c = 10^{-4} \text{ s}^{-1}$
 Find: $M_{\text{tan}} = ? \text{ m/s}$, $Ro_c = ?$ (dimensionless)

Use eq. (10.34a)

$$M_{\text{tan}} = 0.5 \cdot (10^{-4} \text{ s}^{-1}) \cdot (500000 \text{ m}) \cdot \left[-1 + \sqrt{1 + \frac{4 \cdot (10 \text{ m/s})}{(10^{-4} \text{ s}^{-1}) \cdot (500000 \text{ m})}} \right] = \underline{8.54 \text{ m/s}}$$

Use eq. (10.35):

$$Ro_c = \frac{(10 \text{ m/s})}{(10^{-4} \text{ s}^{-1}) \cdot (5 \times 10^5 \text{ m})} = \underline{0.2}$$

Check: Units OK. Physics OK.

Discussion: The small Rossby number indicates that the flow is in geostrophic balance. The gradient wind is indeed slower than geostrophic around this low.

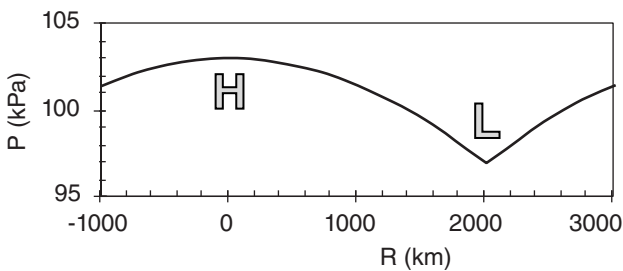

Figure 10.14

Variation of surface pressure across an anticyclone (H) and cyclone (L), showing that the curve can have steep pressure gradients near the low and a cusp at the low, but not at the high. Arbitrary center pressures of 103 kPa and 97 kPa were chosen to illustrate the anticyclone and cyclone, respectively.

Solving the quadratic equation (10.33) for the **cyclonic** flow (around a low-pressure center) yields the gradient wind M_{tan} :

$$M_{\text{tan}} = 0.5 \cdot f_c \cdot R \cdot \left[-1 + \sqrt{1 + \frac{4 \cdot G}{f_c \cdot R}} \right] \quad \bullet(10.34a)$$

For **anticyclonic** flow (around a high-pressure center):

$$M_{\text{tan}} = 0.5 \cdot f_c \cdot R \cdot \left[1 - \sqrt{1 - \frac{4 \cdot G}{f_c \cdot R}} \right] \quad \bullet(10.34b)$$

A “curvature” **Rossby number** (Ro_c) can be defined that uses the radius of curvature (R) as the relevant length scale:

$$Ro_c = \frac{G}{f_c \cdot R} \quad (10.35)$$

[Neither R nor Ro_c are the “Rossby deformation radius” (see eq. 10.70, and the Airmasses, Fronts, and Extratropical Cyclones chapters).] Small values of the **Rossby number** indicate flow that is nearly in geostrophic balance.

The cyclonic gradient wind (around a low) is:

$$M_{\text{tan}} = \frac{G}{2 \cdot Ro_c} \cdot \left[-1 + (1 + 4 \cdot Ro_c)^{1/2} \right] \quad (10.36a)$$

and anticyclonic gradient wind (around a high) is:

$$M_{\text{tan}} = \frac{G}{2 \cdot Ro_c} \cdot \left[1 - (1 - 4 \cdot Ro_c)^{1/2} \right] \quad (10.36b)$$

where G is the geostrophic wind.

For high-pressure centers, steady-state physical (non-imaginary) solutions exist only for $Ro_c \leq 1/4$. Thus, around anticyclones, isobars cannot be both closely spaced and sharply curved. In other words, the pressure cannot decrease rapidly away from high centers. There is no analogous restriction on cyclones, because any value of Ro_c is possible. Thus, pressure gradients and winds must be gentle in highs, but can be vigorous near low centers (Figs. 10.14 and 10.15).

By combining the definition of the Rossby number with that for geostrophic wind, and setting $Ro_c = 1/4$, we find that the maximum horizontal variations of pressure P or height z near anticyclones are:

$$z = z_c - (f_c^2 \cdot R^2) \quad \bullet(10.37a)$$

$$P = P_c - (\rho \cdot f_c^2 \cdot R^2) \quad \bullet(10.37b)$$

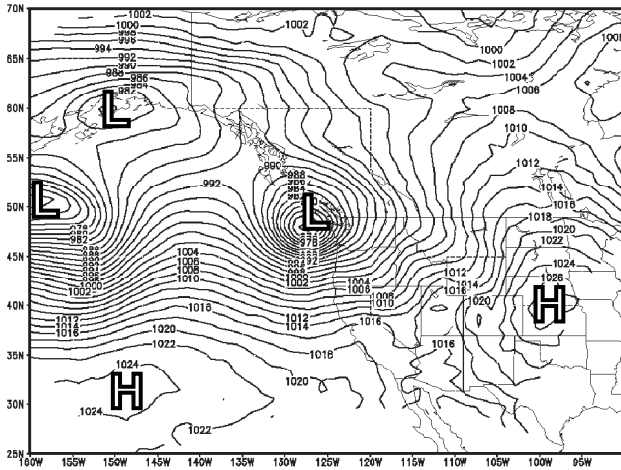

Figure 10.15
Sea-level pressure (contoured every 2 mb= 0.2 kPa), for 00 UTC on 24 Nov 1998. Notice the tight packing of isobars around lows, but looser spacing near high-pressure centers.

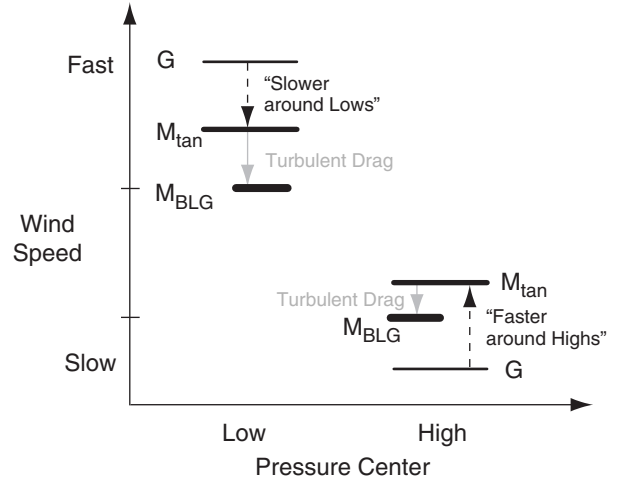

Figure 10.16
Relative magnitudes of different wind speeds around low- and high-pressure centers. G = geostrophic wind, M_{tan} = gradient wind speed, M_{BLG} = boundary-layer gradient wind speed. G is smaller in highs than in lows, because it is not physically possible to have strong pressure gradients to drive strong steady-state winds at high centers.

where z_c and P_c are the reference height or pressure at the center of the anticyclone, f_c is the Coriolis parameter, $|g|$ is gravitational acceleration magnitude, ρ is air density, and R is distance from the center of the anticyclone (Fig. 10.14).

Figs. 10.14 and 10.15 show that pressure gradients, and thus the geostrophic wind, can be large near low centers. However, pressure gradients, and thus the geostrophic wind, must be small near high centers. This difference in geostrophic wind speed G between lows and highs is sketched in Fig. 10.16. The slowdown of gradient wind M_{tan} (relative to geostrophic) around lows, and the speedup of gradient wind (relative to geostrophic) around highs is also plotted in Fig. 10.16. The net result is that gradient winds, and even boundary-layer gradient winds M_{BLG} (described later in this chapter), are usually stronger (in an absolute sense) around lows than highs. For this reason, low-pressure centers are often windy.

Boundary-Layer Wind

Turbulent drag in the boundary layer slows the wind below the geostrophic value, and turns the wind to point at a small angle (α) across the isobars toward low pressure (Fig. 10.17). For flow along straight isobars, the steady-state equations of motion become:

$$0 = -\frac{1}{\rho} \cdot \frac{\Delta P}{\Delta x} + f_c \cdot V - w_T \cdot \frac{U}{z_i} \tag{10.38a}$$

$$0 = -\frac{1}{\rho} \cdot \frac{\Delta P}{\Delta y} - f_c \cdot U - w_T \cdot \frac{V}{z_i} \tag{10.38b}$$

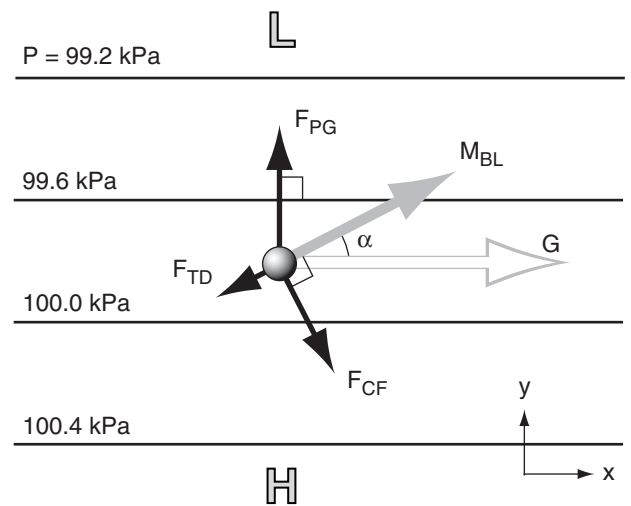

Figure 10.17
Balance of forces (black arrows) creating a boundary-layer wind (M_{BL} , solid grey arrow) that is slower than geostrophic (G , hollow grey arrow). The grey sphere represents an air parcel. Thin black lines are isobars. L and H are low and high-pressure centers.

Solved Example

Find the boundary-layer winds given $U_g = 10 \text{ m/s}$, $V_g = 0$, $z_i = 1 \text{ km}$, $C_D = 0.002$, and $f_c = 10^{-4} \text{ s}^{-1}$. Also, what angle do the winds cross the isobars? This is a statically neutral boundary layer.

Solution

Given: (see above)

Find: $U_{BL} = ? \text{ m/s}$, $V_{BL} = ? \text{ m/s}$, $M_{BL} = ? \text{ m/s}$, $\alpha = ?^\circ$

Use eqs. (10.41): with $G = (U_g^2 + V_g^2)^{1/2} = 10 \text{ m/s}$

$$a = \frac{0.003}{(10^{-4} \text{ s}^{-1}) \cdot (1500 \text{ m})} = 0.02 \text{ s/m}$$

Check: $a \cdot G = (0.02 \text{ s/m}) \cdot (10 \text{ m/s}) = 0.2$ (is < 1 . Good.)

$$U_{BL} = [1 - 0.35 \cdot (0.02 \text{ s/m}) \cdot (10 \text{ m/s})] \cdot (10 \text{ m/s}) \approx \mathbf{9.3 \text{ m/s}}$$

$$V_{BL} = [1 - 0.5 \cdot (0.02 \text{ s/m}) \cdot (10 \text{ m/s})] \cdot (0.02 \text{ s/m}) \cdot (10 \text{ m/s}) \cdot (10 \text{ m/s}) \approx \mathbf{1.8 \text{ m/s}}$$

$$M_{ABL} = \sqrt{U_{ABL}^2 + V_{ABL}^2} = \sqrt{13.4^2 + 1.8^2} \approx \mathbf{13.5 \text{ m/s}}$$

$$M_{ABL} = \sqrt{U_{ABL}^2 + V_{ABL}^2} = \sqrt{13.4^2 + 1.8^2} \approx \mathbf{13.5 \text{ m/s}}$$

The geostrophic wind is parallel to the isobars.

The angle between BL wind and geostrophic is

$$\alpha = \tan^{-1}(V_{BL}/U_{BL}) = \tan^{-1}(1.8/9.3) = \mathbf{11^\circ}$$

Check: Units OK. Physics OK.

Discussion: The boundary-layer wind speed is indeed slower than geostrophic (9.3 vs. 10 m/s), but only slightly slower because the drag coefficient for this example was very small. Also, it crosses the isobars slightly toward low pressure. (The geostrophic wind toward the east means low pressure is to the north.)

Solved Example

Find the boundary layer winds given $U_g = 10 \text{ m/s}$, $V_g = 0$, $z_i = 1 \text{ km}$, $w_B = 45 \text{ m/s}$, $b_D = 1.83 \times 10^{-3}$, and $f_c = 10^{-4} \text{ s}^{-1}$. Also, at what angle does the wind cross the isobars? This is a statically unstable boundary layer.

Solution

Given: (see above, for a convective BL)

Find: $U_{BL} = ? \text{ m/s}$, $V_{BL} = ? \text{ m/s}$, $M_{BL} = ? \text{ m/s}$, $\alpha = ?^\circ$

Use eqs. (10.42):

$$c_1 = \frac{(1.83 \times 10^{-3}) \cdot (50 \text{ m/s})}{(10^{-4} \text{ s}^{-1}) \cdot (1500 \text{ m})} = 0.824 \text{ (dimensionless)}$$

$$c_2 = 1/[1 + (0.824)^2] = 0.60 \text{ (dimensionless)}$$

$$U_{BL} = 0.6 \cdot [(10 \text{ m/s}) - 0] = \mathbf{6.0 \text{ m/s}}$$

$$V_{BL} = 0.6 \cdot [0 + (0.824) \cdot (10 \text{ m/s})] = \mathbf{4.94 \text{ m/s}}$$

Use eq. (10.40):

$$M_{BL} = [U_{BL}^2 + V_{BL}^2]^{1/2} = \mathbf{7.77 \text{ m/s}}$$

$$\alpha = \tan^{-1}(V_{BL}/U_{BL}) = \tan^{-1}(4.94/6.0) = \mathbf{39.5^\circ}$$

Check: Units OK. Physics OK.

Discussion: As before, the boundary layer winds are subgeostrophic, and cross the isobars toward low pressure. Turbulent drag has similar effects, regardless of whether the turbulence is generated mechanically by wind shear, or by buoyant rising thermals.

Namely, the only forces acting for this special case are pressure gradient, Coriolis, and turbulent drag (Fig. 10.17).

Define $U_{BL} = U$ and $V_{BL} = V$ as components of the boundary-layer wind. An implicit solution of eqs. (10.38) is:

$$U_{ABL} = U_g - \frac{w_T \cdot V_{AI}}{f_c \cdot z_i} \tag{10.39a}$$

$$V_{ABL} = V_g + \frac{w_T \cdot U_{AI}}{f_c \cdot z_i} \tag{10.39b}$$

where (U_g, V_g) are geostrophic wind components, f_c is Coriolis parameter, z_i is ABL depth, and w_T is the turbulent transport velocity.

Eqs. (10.39) can be solved by iteration (guess V_{BL} and plug into the first equation, solve for U_{BL} and plug into second equation, solve for V_{BL} and repeat the process). The magnitude of the boundary-layer wind is:

$$M_{BL} = [U_{BL}^2 + V_{BL}^2]^{1/2} \tag{10.40}$$

If the boundary layer is statically **neutral** with strong wind shear, then $w_T = C_D \cdot M_{BL}$, where C_D is the drag coefficient (see eq. 10.21). An approximate explicit solution for the wind at most altitudes in the boundary layer is:

$$\bullet(10.41a)$$

$$U_{ABL} \approx (1 - 0.35 \cdot a \cdot U_g) \cdot U_g - (1 - 0.5 \cdot a \cdot V_g) \cdot a \cdot V_g \cdot G$$

$$\bullet(10.41b)$$

$$V_{ABL} \approx (1 - 0.5 \cdot a \cdot U_g) \cdot a \cdot G \cdot U_g + (1 - 0.35 \cdot a \cdot V_g) \cdot V_g$$

for $a \cdot G < 1$, where $a = C_D/(f_c \cdot z_i)$ and G is the geostrophic wind speed. If this condition is not met, or if no reasonable solution can be found using eqs. (10.41), then use the iterative approach described in the next section, but with the centrifugal terms set to zero. Eqs. (10.41) do not apply to the **surface layer** (bottom 10% of the neutral boundary layer).

For a statically **unstable** boundary layer with light winds, use $w_T = b_D \cdot w_B$ (see eq. 10.22). An exact explicit solution for the winds at most altitudes in the boundary layer is:

$$U_{ABL} = c_2 \cdot [U_g - c_1 \cdot V_g] \tag{10.42a}$$

$$V_{ABL} = c_2 \cdot [V_g + c_1 \cdot U_g] \tag{10.42b}$$

$$\text{where } c_1 = \frac{b_D \cdot w_B}{f_c \cdot z_i}, \text{ and } c_2 = \frac{1}{[1 + c_1^2]}$$

Again, this solution does not apply to the **surface layer** (bottom 5% of convective boundary layer). See the "Forces" section earlier in this chapter for definitions of the factors in c_1 .

Thus, for both neutral and unstable static stabilities, boundary-layer winds (for most mid-boundary-layer altitudes) cross the isobars at a small angle (α) toward low pressure. This cross-isobaric flow occurs for both straight and curved isobars.

Boundary-Layer Gradient (BLG) Wind

In regions of curved isobars at the bottom of cyclones and anticyclones, drag force exists in the boundary layer (BL) in addition to pressure gradient and Coriolis force. The imbalance (F_{net}) of these forces creates a centripetal force that causes the air to spiral in towards low-pressure centers (Fig. 10.18) and spiral out from high-pressure centers. Fig. 10.1 shows a sketch of the BL gradient winds in the N. Hemisphere, and the associated isobars.

Assume steady state, neglect advection, and require an imbalance of forces equal to the centrifugal force, to reduce the equations of motion to:

$$0 = -\frac{1}{\rho} \cdot \frac{\Delta P}{\Delta x} + f_c \cdot V - w_T \cdot \frac{U}{z_i} + s \cdot \frac{V \cdot M}{R} \tag{10.43a}$$

$$0 = -\frac{1}{\rho} \cdot \frac{\Delta P}{\Delta y} - f_c \cdot U - w_T \cdot \frac{V}{z_i} - s \cdot \frac{U \cdot M}{R} \tag{10.43b}$$

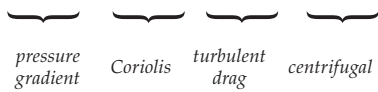

Without actually solving these equations, we can anticipate the following from our previous understanding of geostrophic, gradient, and boundary-layer winds. Boundary-layer gradient (BLG) wind speed is slower than the gradient wind speed due to the drag. The BLG winds flow counterclockwise around lows in the N. Hemisphere, and clockwise around highs. Instead of blowing parallel to the curved isobars like the gradient wind, BLG winds cross the isobars at a small angle (α , tens of degrees) toward low pressure (Fig. 10.19).

The turbulent drag term is different for highs and lows. Winds are strong around lows and skies are often overcast, hence the transport velocity is best represented by the statically neutral parameterization:

$$w_T = C_D \cdot M = C_D \cdot [U^2 + V^2]^{1/2} \tag{10.21 again}$$

which adds even more nonlinearity to eqs. (10.43).

In highs, winds are light and skies are clear, suggesting that transport velocity should be given by the statically unstable parameterization during daytime by:

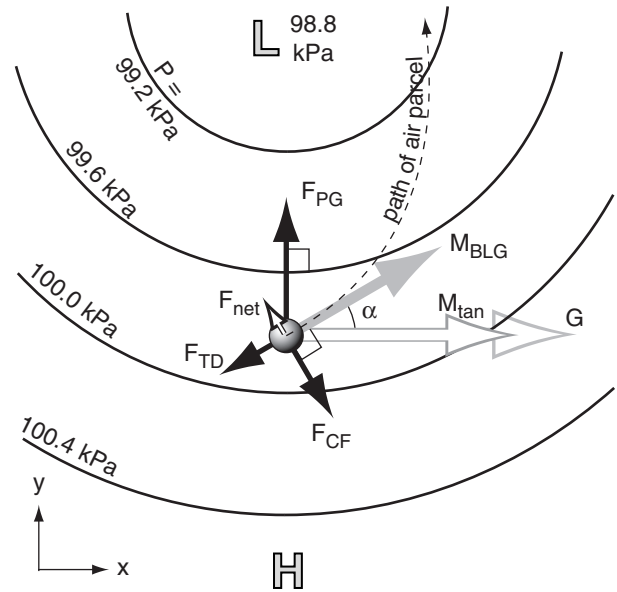

Figure 10.18

Imbalance of forces (black arrows) yield a net centripetal force (F_{net}) that causes the boundary layer gradient wind (M_{BLG} , solid grey arrow) to be slower than both the gradient wind (M_{tan}) and geostrophic wind (G). The resulting air-parcel path crosses the isobars at a small angle α toward low pressure.

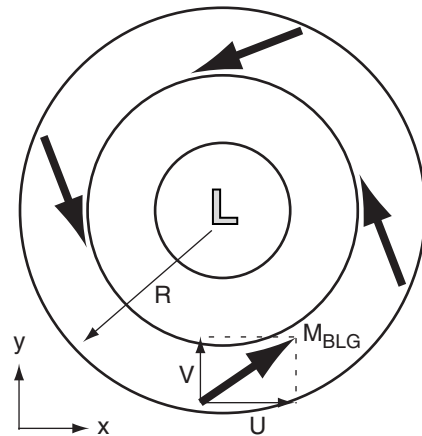

Figure 10.19

Tangential (U) and radial (V) components of the BLG wind in the N. Hemisphere, for that one vector south of the Low.

Solved Example

Find the BLG winds south of a low pressure center in the N. Hemisphere, given $G = 20$ m/s at radius $R = 500$ km from the low center, $z_i = 1$ km, $C_D = 0.01$, and $f_c = 10^{-4} \text{ s}^{-1}$. Also, find the speed.

Solution

Given: (see above)

Find: $U_{BLG} = ?$ m/s, $V_{BLG} = ?$ m/s, $M_{BLG} = ?$ m/s

Use eqs. (1.1) and (10.44) in a spreadsheet. Set the time step to $\Delta t = 1$ h. Choose $U = 0$ and $V = 0$ as the first guess. Make 20 iterations (see the Focus box).

Iteration	U (m/s)	V (m/s)	M (m/s)	delta U	delta V
0	0.00	0.00	0.00	0.000	7.200
1	0.00	7.20	7.20	2.965	5.334
2	2.97	12.53	12.88	4.300	0.046
3	7.26	12.58	14.53	2.045	-2.754
4	9.31	9.83	13.54	-0.042	-1.847
5	9.27	7.98	12.23	-0.506	-0.465
6	8.76	7.51	11.54	-0.312	0.195
7	8.45	7.71	11.44	-0.070	0.288
8	8.38	8.00	11.58	0.051	0.150
9	8.43	8.15	11.72	0.062	0.015
10	8.49	8.16	11.78	0.029	-0.038
11	8.52	8.12	11.77	0.001	-0.033
12	8.52	8.09	11.75	-0.009	-0.012
13	8.51	8.08	11.74	-0.007	0.002
14	8.51	8.08	11.73	-0.002	0.005
15	8.51	8.09	11.74	0.001	0.003
16	8.51	8.09	11.74	0.001	0.001
17	8.51	8.09	11.74	0.001	-0.001
18	8.51	8.09	11.74	0.000	-0.001
19	8.51	8.09	11.74	0.000	0.000
20	8.51	8.09	11.74	0.000	0.000

$U_{BLG} = 8.51$ m/s, $V_{BLG} = 8.09$ m/s, $M_{BLG} = 11.74$ m/s, where (U_{BLG}, V_{BLG}) are (tangential, radial) parts.

Check: Units OK. Physics OK. Check that the computed wind approaches the: (1) geostrophic wind as R approaches ∞ , with $C_D = 0$; (2) gradient wind when $C_D = 0$; (3) boundary-layer wind when R approaches ∞ .

I performed these checks using a modified spreadsheet that relaxed the results using a weighted average of new and previous winds, and found: (1) for geostrophic: $U_{BLG} = G = 20$ m/s, $V_{BLG} = 0$; (2) for gradient: $U_{BLG} = 15.31$ m/s, $V_{BLG} = 0$; and (3) for BL: $U_{BLG} = 7.81$ m/s, $V_{BLG} = 9.76$ m/s. This BL solution is the exact solution; it is better than approximate eqs. (10.41).

Discussion: The solution converges toward the BLG wind, as if an air parcel started from rest and began accelerating. The Fig. at right used $\Delta t = 1000$ s (not 1 h). Starting at zero wind speed, each dot shows the wind forecast for the next time step in the iteration.

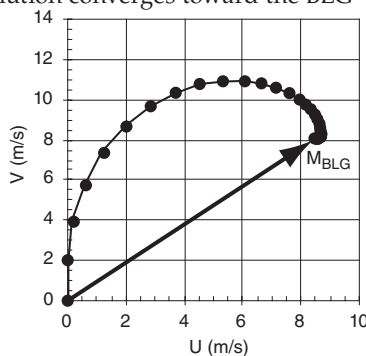

$$w_T = b_D \cdot w_B \quad (10.22 \text{ again})$$

where w_B is not a function of wind speed. For statically stable conditions at night in fair weather, steady state is unlikely, so eqs. (10.43) are invalid.

While the equations of motion for geostrophic and gradient winds were simple enough to allow an analytical solution, and we could devise an approximate analytical solution for the BL wind, we are not so lucky with the BLG wind. The set of coupled equations (10.43) are nonlinear and nasty to solve.

Nonetheless, we can numerically iterate towards the answer by including the tendency term on the LHS of each equation. For example, $LHS = \Delta U / \Delta t = [U(t+\Delta t) - U(t)] / \Delta t$. Also, rewrite eqs. (10.43) in cylindrical coordinates, letting U be the tangential component, and V be the radial component (Fig. 10.19). Use geostrophic wind G as a surrogate for the radial pressure gradient.

For BLG winds around a low in the N. Hemisphere (i.e., $s = +1$), equations (10.43) can be rewritten as the following set of coupled equations, which is valid day or night:

$$M = (U^2 + V^2)^{1/2} \quad (1.1 \text{ again})$$

$$U(t + \Delta t) = U + \Delta t \cdot \left[f_c \cdot V - \frac{C_D \cdot M \cdot U}{z_i} + s \frac{V \cdot M}{R} \right] \quad (10.44a)$$

$$V(t + \Delta t) = V + \Delta t \cdot \left[f_c \cdot (G - U) - \frac{C_D \cdot M \cdot V}{z_i} - s \frac{U \cdot M}{R} \right] \quad (10.44b)$$

where (U, V) represent (tangential, radial) parts for the wind vector south of the low center.

FOCUS • Solution by Iteration

Equations (10.44) are difficult to solve analytically, but we can iterate as an alternative way to solve for the BLG wind components. To use this approach:

- (1) Make a first guess that $(U, V) = (0, 0)$.
- (2) Plug in these values everywhere that $U, U(t), V,$ or $V(t)$ appears in eqs. (1.1) and (10.44).
- (3) Solve eqs. (10.44) for the new values of $[U(t+\Delta t), V(t+\Delta t)]$.
- (4) Repeat steps 2 & 3, but using the new winds.
- (5) Continue until the $[U(t+\Delta t), V(t+\Delta t)]$ wind components converge to steady values, which by definition are the (U_{BLG}, V_{BLG}) components that we want.

Iterative approaches are tedious when done on a hand calculator, so use a spreadsheet or computer program instead, such as was done in the solved example.

Similar equations can be derived for convective boundary layers in high-pressure regions.

You can use the iterative method described in the Focus box to solve equations (10.44). In the solved example, notice that the spreadsheet iterations do not proceed directly to the final solution, but spiral toward it. This spiral is called a **damped inertial oscillation**.

Equations (10.44) are also valid for unsteady (time varying) solutions, such as at night. At night when drag is weak, the winds may never reach steady state, and may continue as undamped or weakly-damped **inertial oscillations** (see a previous Focus Box on *Approach to Geostrophy*). Such oscillations can temporarily cause winds to be greater than geostrophic in regions of straight isobars, or greater than gradient in regions of curved isobars. This is one reason for the **supergeostrophic nocturnal jet**, which will be covered in the Atmospheric Boundary Layer chapter.

Cyclostrophic Wind

In intense vortices, strong winds rotate around a very tight circle. Winds in tornadoes are about 100 m/s, and in water spouts are about 50 m/s. As the tornado strengthens and tangential winds increase, centrifugal force increases much more rapidly than Coriolis force. Centrifugal force quickly becomes the dominant force that balances pressure-gradient force (Fig. 10.20). Thus, a steady-state rotating wind is reached at much slower speeds than the gradient wind speed.

For steady state winds, the equations of motion reduce to:

$$0 = -\frac{1}{\rho} \cdot \frac{\Delta P}{\Delta x} + s \cdot \frac{V \cdot M}{R} \tag{10.45a}$$

$$0 = \underbrace{-\frac{1}{\rho} \cdot \frac{\Delta P}{\Delta y}}_{\text{pressure gradient}} - \underbrace{s \cdot \frac{U \cdot M}{R}}_{\text{centrifugal}} \tag{10.45b}$$

Because of the cylindrical nature of these flows as they rotate around intense low-pressure centers, it is easier to write and solve the equations for cyclostrophic wind M_{cs} in cylindrical form:

$$M_{cs} = \sqrt{\frac{R}{\rho} \cdot \frac{\Delta P}{\Delta R}} \tag{10.46}$$

where R is radial distance outward from the center of rotation, $\Delta P/\Delta R$ is the local radial pressure gradient, and M_{cs} is the tangential speed.

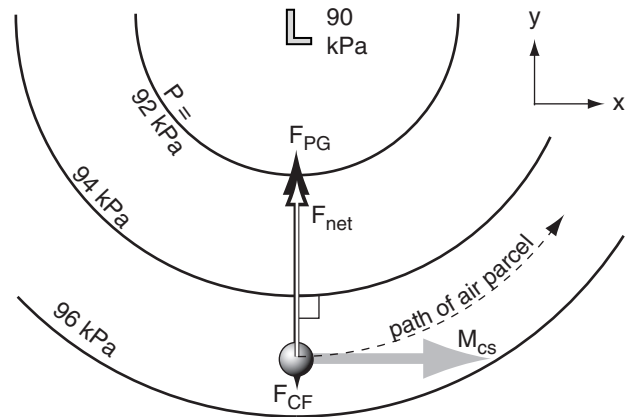

Figure 10.20
Around tornadoes, pressure gradient force is so strong that it greatly exceeds all other forces. The net force (F_{net}) pulls the air around the tight circle at the cyclostrophic wind speed (M_{cs}).

Solved Example

A 10 m radius waterspout has a tangential velocity of 45 m/s. What is the radial pressure gradient?

Solution

Given: $M_{cs} = 45 \text{ m/s}$, $R = 10 \text{ m}$.

Find: $\Delta P/\Delta R = ? \text{ kPa/m}$.

Assume cyclostrophic wind, and $\rho = 1 \text{ kg/m}^3$. Rearrange eq. (10.46):

$$\frac{\Delta P}{\Delta R} = \frac{\rho}{R} \cdot M_{cs}^2 = \frac{(1 \text{ kg/m}^3) \cdot (45 \text{ m/s})^2}{10 \text{ m}}$$

$$\Delta P/\Delta R = 202.5 \text{ kg} \cdot \text{m}^{-1} \cdot \text{s}^{-2} / \text{m} = \mathbf{0.2 \text{ kPa/m}}$$

Check: Units OK. Physics OK.

Discussion: This is 2 kPa across the 10 m waterspout radius, which is 1000 times greater than typical synoptic-scale pressure gradients on weather maps.

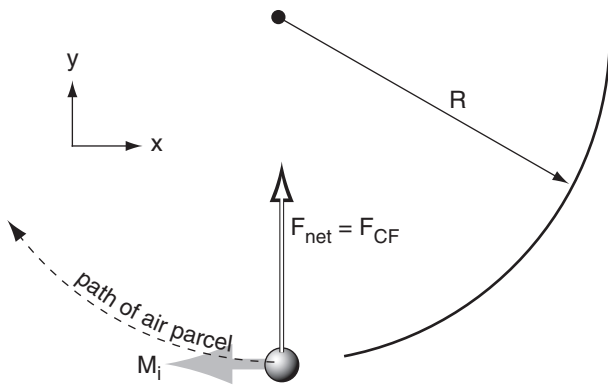

Figure 10.21
Imbalance of forces (F , black arrows) on an air parcel (grey ball), creating an anticyclonic inertial wind M_i , grey arrow). R is radius of curvature, and F_{CF} is Coriolis force.

Solved Example

For an inertial ocean current of 5 m/s, find the radius of curvature and time period to complete one circuit. Assume a latitude where $f_c = 10^{-4} \text{ s}^{-1}$.

Solution

Given: $M_i = 5 \text{ m/s}$, $f_c = 10^{-4} \text{ s}^{-1}$.
Find: $R = ? \text{ km}$, $P = ? \text{ h}$

Use eq. (10.48): $R = -(5 \text{ m/s}) / (10^{-4} \text{ s}^{-1}) = \mathbf{-50 \text{ km}}$
Use $P = 2\pi/f_c = 62832 \text{ s} = \mathbf{17.45 \text{ h}}$

Check: Units OK. Magnitudes OK.

Discussion: The tracks of drifting buoys in the ocean are often **cycloidal**, which is the superposition of a circular inertial oscillation and a mean current that gradually moves the whole circle.

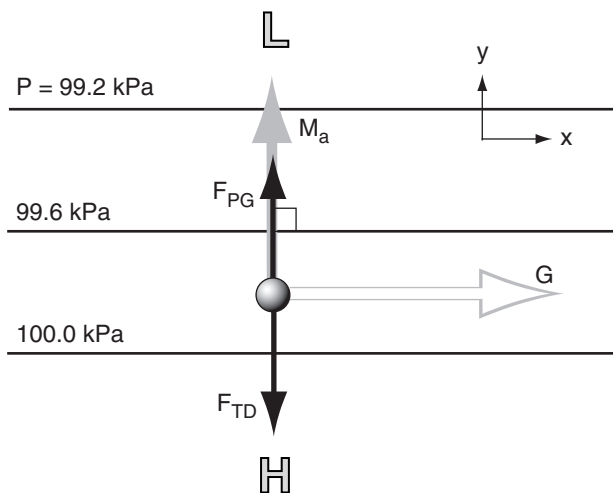

Figure 10.22
Balance of forces (F , black arrows) that create the antitriptic wind M_a (grey arrow). G is the theoretical geostrophic wind. F_{TD} is turbulent drag, and F_{PG} is pressure-gradient force.

Cyclostrophic winds never occur around high pressure centers, because the strong pressure gradients needed to drive such winds are not possible. Around lows, cyclostrophic winds can turn either counterclockwise or clockwise in either hemisphere, because Coriolis force is not a factor.

Inertial Wind

Steady-state **inertial motion** results from a balance of Coriolis and centrifugal forces:

$$0 = f_c \cdot M_i + \frac{M_i^2}{R} \tag{10.47}$$

where M_i is inertial wind speed, f_c is the Coriolis parameter, and R is the radius of curvature. Since both of these forces depend on wind speed, the inertial wind cannot start itself from zero. It can occur only after some additional force first causes the wind to blow, and then that extra force disappears.

The inertial wind coasts around a circular path of radius R ,

$$R = -\frac{M_i}{f_c} \tag{10.48}$$

where the negative sign implies anticyclonic rotation (Fig. 10.21). The time period needed for this **inertial oscillation** to complete one circuit is $P = 2\pi/f_c$, which is half of a **pendulum day** (see *Approach to Geostrophy* Focus Box earlier in this chapter).

Although rarely observed in the atmosphere, inertial oscillations are frequently observed in the ocean. This can occur where wind stress on the ocean surface creates an ocean current, and then after the wind dies the current coasts in an inertial oscillation.

Antitriptic Wind

A steady-state antitriptic wind M_a could result from a balance of pressure-gradient force and turbulent drag:

$$0 = -\frac{1}{\rho} \cdot \frac{\Delta P}{\Delta d} - w_T \cdot \frac{M_a}{z_i} \tag{10.49}$$

where ΔP is the pressure change across a distance Δd perpendicular to the isobars, f_c is the Coriolis parameter, w_T is the turbulent transport velocity, and z_i is boundary-layer depth.

This wind blows perpendicular to the isobars (Fig. 10.22), directly from high to low pressure:

$$M_a = \frac{z_i \cdot f_c \cdot G}{w_T} \tag{10.50}$$

For free-convective boundary layers, $w_T = b_D \cdot w_B$ is not a function of wind speed, so M_a is proportional to G . However, for windy forced-convection boundary layers, $w_T = C_D \cdot M_a$, so solving for M_a shows it to be proportional to the square root of G .

This wind would be found in the boundary layer, and occurs as an along-valley component of “long gap” winds (see the Local Winds chapter). It is also sometimes thought to be relevant for thunderstorm cold-air outflow and for steady sea breezes. However, in most other situations, Coriolis force should not be neglected; thus, the boundary-layer wind and BL Gradient winds are much better representations of nature than the antitriptic wind.

Summary of Horizontal Winds

Table 10-5 summarizes the idealized horizontal winds that were discussed earlier in this chapter.

On real weather maps such as Fig. 10.23, isobars or height contours have complex shapes. In some regions the height contours are straight (suggesting that actual winds should nearly equal geostrophic or boundary-layer winds), while in other regions the height contours are curved (suggesting gradient or boundary-layer gradient winds). Also, as air parcels move between straight and curved regions, they are sometimes not quite in equilibrium. Nonetheless, when studying weather maps you can quickly estimate the winds using the summary table.

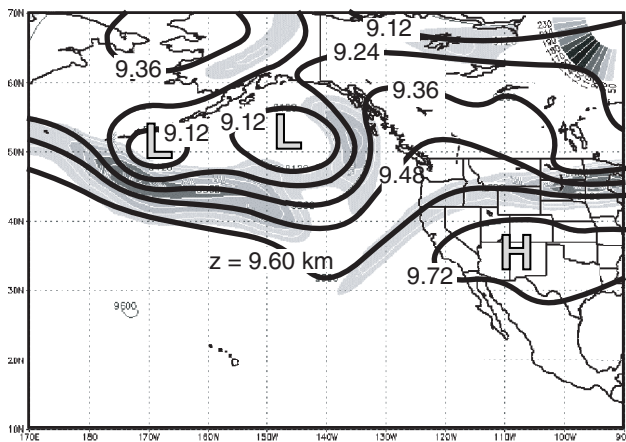

Figure 10.23
Upper-air 30 kPa height chart valid at 12 UTC on 9 July 99. Shading indicates isotachs in the jet stream, where light grey denotes roughly 25 m/s or greater winds, and darker shading is roughly 50 m/s or greater. Thick lines are height contours. Faster winds occur where contours are packed. [Adapted from a US Navy Fleet Numerical Meteor. and Ocean. Ctr. chart.]

Solved Example

In a 1 km thick convective boundary layer at a location where $f_c = 10^{-4} \text{ s}^{-1}$, the geostrophic wind is 5 m/s. The turbulent transport velocity is 0.02 m/s. Find the antitriptic wind speed.

Solution

Given: $G = 5 \text{ m/s}$, $z_i = 1000 \text{ m}$, $f_c = 10^{-4} \text{ s}^{-1}$,
 $w_T = 0.02 \text{ m/s}$
Find: $M_a = ? \text{ m/s}$

Use eq. (10.50):

$$M_a = (1000\text{m}) \cdot (10^{-4} \text{ s}^{-1}) \cdot (5\text{m/s}) / (0.2 \text{ m/s})$$

$$= \underline{25 \text{ m/s}}$$

Check: Magnitude seems too large. Units OK.

Discussion: Eq. (10.50) can give winds of $M_a > G$ for many convective conditions, for which case Coriolis force would be expected to be large enough that it should not be neglected. Thus, antitriptic winds are unphysical. However, for forced-convective boundary layers where drag is proportional to wind speed squared, reasonable solutions are possible.

FOCUS • The Rossby Number

The **Rossby number** (Ro) is a dimensionless ratio defined by

$$Ro = \frac{M}{f_c \cdot L} \quad \text{or} \quad Ro = \frac{M}{f_c \cdot R}$$

where M is wind speed, f_c is the Coriolis parameter, L is a characteristic length scale, and R is radius of curvature.

In the equations of motion, suppose that advection terms such as $U \cdot \Delta U / \Delta x$ are order of magnitude M^2/L , and Coriolis terms are of order $f_c \cdot M$. Then the Rossby number is like the ratio of advection to Coriolis terms: $(M^2/L) / (f_c \cdot M) = M / (f_c \cdot L) = Ro$. Or, we could consider the Rossby number as the ratio of centrifugal (order of M^2/R) to Coriolis terms, yielding $M / (f_c \cdot R) = Ro$.

Use the Rossby number as follows. If $Ro < 1$, then Coriolis force is a dominant force, and the flow tends to become geostrophic (or gradient, for curved flow). If $Ro > 1$, then the flow tends not to be geostrophic.

For example, a midlatitude cyclone (low-pressure system) has approximately $M = 10 \text{ m/s}$, $f_c = 10^{-4} \text{ s}^{-1}$, and $R = 1000 \text{ km}$, which gives $Ro = 0.1$. Hence, midlatitude cyclones tend to adjust toward geostrophic balance, because $Ro < 1$. In contrast, a tornado has roughly $M = 50 \text{ m/s}$, $f_c = 10^{-4} \text{ s}^{-1}$, and $R = 50 \text{ m}$, which gives $Ro = 10,000$, which is so much greater than one that geostrophic balance is not relevant.

Table 10-5. Summary of horizontal winds**.

Item	Name of Wind	Forces	Direction	Magnitude	Where Observed
1	geostrophic	pressure-gradient, Coriolis	parallel to straight isobars with Low pressure to the wind's left*	faster where isobars are closer together. $G = \left \frac{1}{\rho \cdot f_c} \cdot \frac{\Delta P}{\Delta d} \right $	aloft in regions where isobars are nearly straight
2	gradient	pressure-gradient, Coriolis, centrifugal	similar to geostrophic wind, but following curved isobars. Clockwise* around Highs, counterclockwise* around Lows.	slower than geostrophic around Lows, faster than geostrophic around Highs	aloft in regions where isobars are curved
3	boundary layer	pressure-gradient, Coriolis, drag	similar to geostrophic wind, but crosses isobars at small angle toward Low pressure	slower than geostrophic (i.e., subgeostrophic)	near the ground in regions where isobars are nearly straight
4	boundary-layer gradient	pressure-gradient, Coriolis, drag, centrifugal	similar to gradient wind, but crosses isobars at small angle toward Low pressure	slower than gradient wind speed	near the ground in regions where isobars are curved
5	cyclostrophic	pressure-gradient, centrifugal	either clockwise or counterclockwise around strong vortices of small diameter	stronger for lower pressure in the vortex center	tornadoes, waterspouts (& sometimes in the eye-wall of hurricanes)
6	inertial	Coriolis, centrifugal	anticyclonic circular rotation	coasts at constant speed equal to its initial speed	ocean-surface currents

* For Northern Hemisphere. Direction is opposite in Southern Hemisphere. ** Antitriptic winds are unphysical; not listed here.

HORIZONTAL MOTION

Equations of Motion — Revisited

The geostrophic wind can be used as a surrogate for the pressure-gradient force, based on the definitions in eqs. (10.26). With this substitution, we can then group this term with the Coriolis term in the **equations of horizontal motion** (10.23):

$$\frac{\Delta U}{\Delta t} = -U \frac{\Delta U}{\Delta x} - V \frac{\Delta U}{\Delta y} + f_c \cdot (V - V_g) - w_T \cdot \frac{U}{z_i} \quad \bullet(10.51a)$$

$$\frac{\Delta V}{\Delta t} = -U \frac{\Delta V}{\Delta x} - V \frac{\Delta V}{\Delta y} - f_c \cdot (U - U_g) - w_T \cdot \frac{V}{z_i} \quad \bullet(10.51b)$$

⏟
⏟
⏟
⏟
⏟

tendency
horizontal advection
Coriolis
pressure gradient
turbulent drag

To be accurate, an additional vertical advection term should be included in the right-hand side of each equation. Namely, $-W \cdot \Delta U / \Delta z$ in the forecast equation for U wind, and $-W \cdot \Delta V / \Delta z$ in the equation for V wind. For example, fast jet-stream horizontal winds aloft can be advected down toward the surface, causing fast, damaging surface winds. Similarly, slow boundary-layer horizontal winds can be advected upward to spread the effects of surface drag higher into the atmosphere.

A centrifugal term could also be added for winds associated with curved isobars, which is an artifice to account for the continual changing of wind direction caused by an imbalance of the other forces (where the imbalance is the centripetal force).

The third term on the right is called the **geostrophic departure** term. The wind difference is also called the **ageostrophic wind** (U_{ag}, V_{ag}):

$$U_{ag} = U - U_g \quad \bullet(10.52a)$$

$$V_{ag} = V - V_g \quad \bullet(10.52b)$$

Scales of Horizontal Motion

In the atmosphere, motions of many scales are superimposed: from small turbulent eddies through thunderstorms and cyclones to large planetary-scale circulations such as the jet stream. Scales of horizontal motion are classified in Table 10-6.

Small atmospheric phenomena of horizontal dimension less than about 10 km are frequently **isotropic**; namely, their vertical and horizontal dimensions are roughly equal. Horizontally-larger phenomena are somewhat pancake-like, because the vertical dimension is generally limited by the depth of the troposphere (about 11 km).

Fig. 10.24 shows that time scales τ and horizontal length scales λ of many meteorological phenomena early follow a straight line on a log-log plot. This implies that

$$\tau/\tau_0 = (\lambda/\lambda_0)^b \tag{10.53}$$

where $\tau_0 \approx 10^{-3}$ h, $\lambda_0 \approx 10^{-3}$ km, and $b \approx 7/8$. For example, microscale turbulence about 1 m in diameter might last about a 1 s. Boundary-layer thermals of diameter 1 km have circulation lifetimes of about 25 min. Thunderstorms of size 10 km might last a few hours. Cyclones of size 1000 km might last a week.

In the next several chapters, we cover weather phenomena from largest to smallest horiz. scales:

- Chapter 11 Global Circulation (planetary)
- Chapter 12 Airmasses and Fronts (synoptic)
- Chapter 13 Extratropical Cyclones (synoptic)
- Chapter 14 Thunderstorms (meso β)
- Chapter 15 Thunderstorm Hazards (meso γ)
- Chapter 16 Hurricanes (meso α & β)
- Chapter 17 Local Winds (meso β & γ)
- Chapter 18 Atm. Boundary Layers (microscale)

Although hurricanes are larger than thunderstorms, we cover thunderstorms first because they are the building blocks of hurricanes. Similarly, midlatitude cyclones often contain fronts, so fronts are covered before extratropical cyclones.

Table 10-6. Scales of horizontal motion in the troposphere.

Size	Scale	Name	
40,000 km	macro α	planetary scale	
4,000 km	macro β	synoptic scale*	
700 km	meso α	mesoscale**	
300 km	meso β		
30 km	meso γ		
3 km	micro α	microscale***	
300 m	micro β		boundary-layer turbulence
30 m	micro γ		surface-layer turbulence
3 m			inertial subrange turbulence
300 mm	micro δ		fine-scale turbulence
30 mm			
3 mm	viscous	dissipation subrange	
0.3 μ m	molecular	mean-free path between molec.	
0.003 μ m		molecule sizes	
0			

Note: Disagreement among different organizations.
 *Synoptic: AMS: 400 - 4000 km; WMO: 1000 - 2500 km.
 **Mesoscale: AMS: 3 - 400 km; WMO: 3 - 50 km.
 ***Microscale: AMS: 0 - 2 km; WMO: 3 cm - 3 km.
 where AMS = American Meteorological Society, and WMO = World Meteorological Organization.

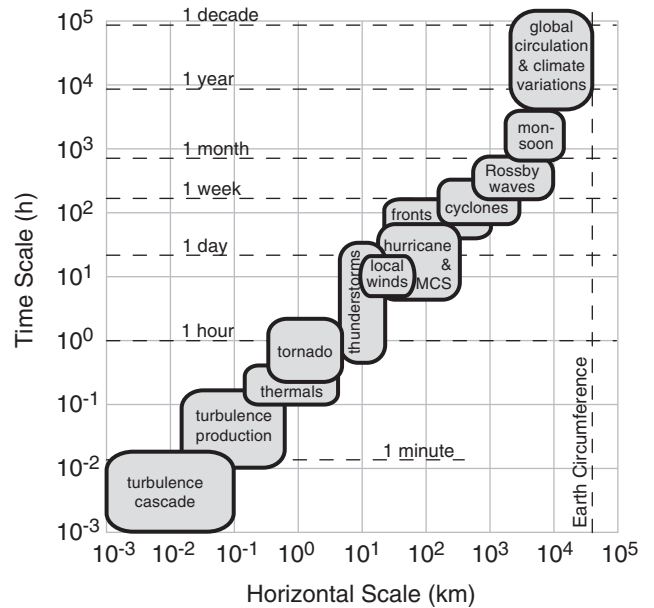

Figure 10.24
 Typical time and spatial scales of meteorological phenomena.

VERTICAL FORCES AND MOTION

Forces acting in the vertical can cause or change vertical velocities, according to Newton's Second Law. In an Eulerian framework, the **vertical component of the equations of motion** is:

$$\frac{\Delta W}{\Delta t} = \underbrace{-U \frac{\Delta W}{\Delta x}}_{\text{tendency}} - \underbrace{V \frac{\Delta W}{\Delta y} - W \frac{\Delta W}{\Delta z}}_{\text{advection}} - \underbrace{\frac{1}{\rho} \frac{\Delta P}{\Delta z}}_{\text{pressure gradient}} - \underbrace{|g|}_{\text{gravity}} - \underbrace{\frac{F_z}{m}}_{\text{turb. drag}} \tag{10.54}$$

Science Graffito

"The book of nature is written in the language of mathematics."
 – Galileo, as paraphrased by Alex Stone, 2005. *Discover*, 26, p77.

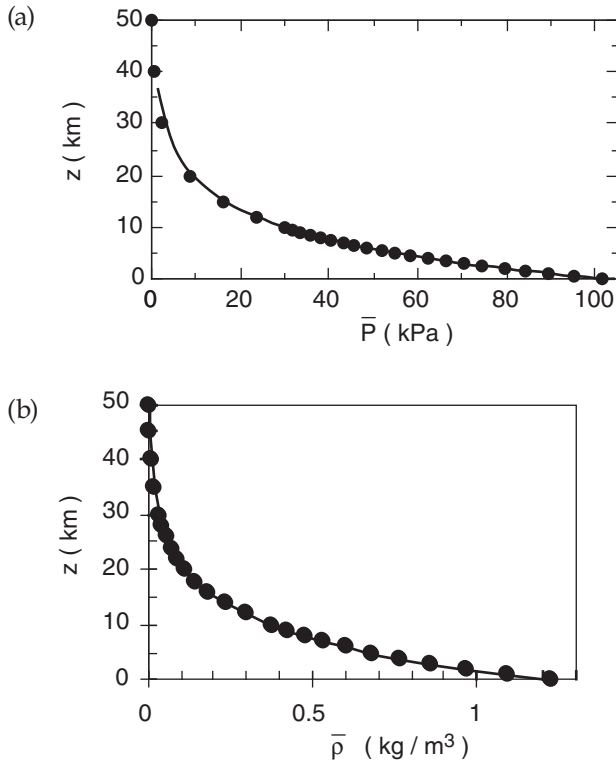

Figure 10.25
Mean background state, showing variations with height z of (a) atmospheric pressure \bar{P} and (b) density $\bar{\rho}$ (from Chapter 1).

where the left hand side is the vertical acceleration, and the right hand side lists the vertical forces per mass. (U, V, W) are the three Cartesian velocity components in the (x, y, z) directions, P is pressure, ρ is air density, t is time, F_z is the turbulent drag force in the vertical, and mass is m . Gravitational acceleration magnitude is $|g| = 9.8 \text{ m}\cdot\text{s}^{-2}$. Coriolis force is negligible in the vertical (see the Focus box on *Coriolis Force in 3-D*, earlier in this chapter), and is not included in the equation above.

Recall from Chapter 1 that our atmosphere has an extremely large pressure gradient in the vertical, which is almost completely balanced by gravity (Fig. 10.25). Also, there is a large density gradient in the vertical. We can define these large terms as a **mean background state** or a **reference state** of the atmosphere. Use the overbar over variables to indicate their average background state. Define this background state such that it is exactly in **hydrostatic balance** (see Chapter 1):

$$\frac{\Delta \bar{P}}{\Delta z} = -\bar{\rho} \cdot |g| \tag{10.55}$$

However, small deviations in density and pressure from the background state can drive important **non-hydrostatic** vertical motions, such as in thermals and thunderstorms. To discern these effects, we must first remove the background state from the full vertical equation of motion. Focus on the pressure-gradient and gravity terms of eq. (10.54), rewritten here as:

$$\frac{1}{\rho} \left[-\frac{\Delta P}{\Delta z} - \rho |g| \right] \tag{10.56}$$

Split the total density ρ into a background ($\bar{\rho}$) and deviation (ρ') part: $\rho = \bar{\rho} + \rho'$. Do the same for pressure: $P = \bar{P} + P'$. The terms above become:

$$\frac{1}{(\bar{\rho} + \rho')} \left[-\frac{\Delta \bar{P}}{\Delta z} - \frac{\Delta P'}{\Delta z} - \bar{\rho} |g| - \rho' |g| \right] \tag{10.57}$$

The first and third terms in square brackets in eq. (10.57) cancel out, due to hydrostatic balance (eq. 10.55) of the background state.

Next, a **Boussinesq approximation** is made that $\rho' |g| / (\bar{\rho} + \rho') \approx \rho' / \bar{\rho}$, which implies that density deviations are important in the gravity term, but negligible for all other terms. This is reasonable because $\rho' \ll \bar{\rho}$. In the Stability chapter, it was shown that density deviations can be described by virtual temperature T_v deviations (with a sign change because low density corresponds to high temperature):

Solved Example

An updraft of 8 m/s exists 2 km west of your location, and there is a west wind of 5 m/s. At your location there is zero vertical velocity, but the air is 3°C warmer than the surrounding environment of 25°C. What is the initial vertical acceleration of the air over your location?

Solution

Given: $\Delta\theta = 3^\circ\text{C}$, $T_e = 273+25 = 298 \text{ K}$, $U = 5 \text{ m/s}$
 $\Delta W/\Delta x = (8 \text{ m/s} - 0) / (-2,000 \text{ m} - 0)$
 Assume: $V = 0$. Drag = 0 initially, given $W = 0$.
 Dry air, thus $T_v = T$.
 Find: $\Delta W/\Delta t = ? \text{ m}\cdot\text{s}^{-2}$

Use eq. (10.59): $\frac{\Delta W}{\Delta t} = -U \frac{\Delta W}{\Delta x} + \frac{\theta_p - \theta_e}{T_e} \cdot |g|$
 $= -(5 \text{ m/s}) \cdot (-8 \text{ m}\cdot\text{s}^{-1} / 2,000 \text{ m}) + (3/298) \cdot (9.8 \text{ m}\cdot\text{s}^{-2})$
 $= 0.020 + 0.099 = 0.119 \text{ m}\cdot\text{s}^{-2}$

Check: Units OK. Physics OK.

Discussion: Extrapolated over a minute, this initial acceleration gives $W = 7.1 \text{ m/s}$. However, this vertical velocity would not be achieved because as soon as the velocity is nonzero, the drag term also becomes nonzero and tends to slow the vertical acceleration.

$$-\frac{\rho'}{\bar{\rho}} \cdot |g| = \frac{\theta'_{ve}}{\bar{T}_{ve}} \cdot |g| = \frac{\theta_{vp} - \theta_{ve}}{\bar{T}_{ve}} \cdot |g| = g' \quad (10.58)$$

where subscript *p* denotes the air parcel, and subscript *e* is for the environment, and *g'* is called the **reduced gravity**. \bar{T}_{ve} in the denominator must be in Kelvin.

Plugging this back into eq. (10.54) gives:

$$\frac{\Delta W}{\Delta t} = -U \frac{\Delta W}{\Delta x} - V \frac{\Delta W}{\Delta y} - W \frac{\Delta W}{\Delta z} \quad \bullet(10.59)$$

$$-\frac{1}{\rho} \frac{\Delta P'}{\Delta z} + \frac{\theta_{vp} - \theta_{ve}}{\bar{T}_{ve}} \cdot |g| - \frac{F_{zTD}}{m}$$

Terms from this equation will be used in the Local Winds and Thunderstorms chapters, to explain strong vertical velocities.

Turbulent drag is the resistance of a vertically moving air parcel against other surrounding (stationary environmental) air. This is a completely different effect than drag against the Earth's surface, and is not described by the same drag equations. The nature of F_{zTD} is considered in the chapter on Air Pollution Dispersion, as it affects the rise of smoke-stack plumes. Air with no vertical movement relative to its environment has no drag.

MASS CONSERVATION

Barring any nuclear reactions, air molecules are not converted into energy, and air mass is conserved. In an Eulerian framework, mass flowing into a fixed volume minus the mass flowing out gives the change of mass within the volume (Fig. 10.26). The equation describing this mass balance is called the **continuity equation**. The name "continuity" is based on the observation that gases such as air tend to spread smoothly and evenly within a volume.

Continuity Equation

Recall that mass within a unit volume is defined as density, ρ . The **mass budget** is:

$$\frac{\Delta \rho}{\Delta t} = \left\{ -U \frac{\Delta \rho}{\Delta x} - V \frac{\Delta \rho}{\Delta y} - W \frac{\Delta \rho}{\Delta z} \right\} - \rho \left[\frac{\Delta U}{\Delta x} + \frac{\Delta V}{\Delta y} + \frac{\Delta W}{\Delta z} \right] \quad (10.60)$$

which is also called the **continuity equation**. The terms in curly braces { } describe advection. Eq. (10.60) can be rearranged (using calculus) to be:

FOCUS • Eötvös Effect

When you move along a path at constant distance *R* above Earth's center, gravitational acceleration appears to change slightly due to your motion. The measured gravity $|g_{obs}| = |g| - a_r$, where:

$$a_r = 2 \cdot \Omega \cdot \cos(\phi) \cdot U + (U^2 + V^2)/R$$

The first term is the vertical component of Coriolis force (eq. 10.17e in the Focus box on p.297), and the last term is centrifugal force as you follow the curvature of the Earth. Thus, you feel lighter traveling east and heavier traveling west. This is the **Eötvös effect**.

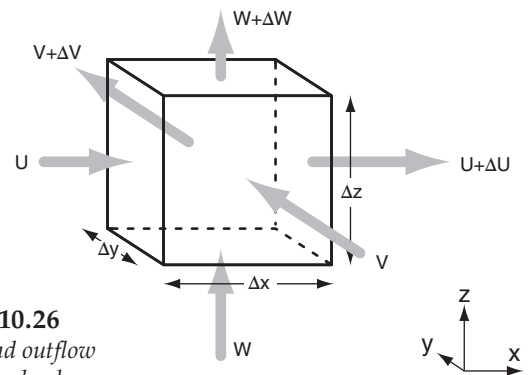

Figure 10.26
Inflow and outflow from a fixed volume.

Solved Example

Just before a tornado strikes your garage, the air density inside is 1 kg/m^3 . Winds of 100 m/s enter the open garage from the west, but nothing leaves from the east. Also, your garage is temporarily intact, so the other walls, floor, and ceiling prevent winds in those other directions. The east end of your garage is 8 m from the open west end. What is the density change in your garage during the first 1 s , neglecting advection?

Solution

Given: $U_{\text{door}} = 100 \text{ m/s}$, $U_{\text{end}} = 0 \text{ m/s}$, $\Delta x = 8 \text{ m}$, $\rho = 1 \text{ kg/m}^3$.

Find: $\Delta \rho / \Delta t = ? \text{ kg} \cdot \text{m}^{-3} \cdot \text{s}^{-1}$.

Use eq. (10.60), with $V = W = 0$ because the other walls, roof, and floor prevent winds in those directions:

$$\frac{\Delta \rho}{\Delta t} = -\rho \frac{V_{N.\text{entr.}} - V_{S.\text{entr.}}}{\Delta y_{\text{tunnel}}} = -\left(1.2 \frac{\text{kg}}{\text{m}^3} \right) \frac{(-60 - 0)}{(20)\text{r}}$$

$$\Delta \rho / \Delta t = +12.5 \text{ kg} \cdot \text{m}^{-3} \cdot \text{s}^{-1}$$

Check: Units OK. Physics OK.

Discussion: Due to Bernoulli's principle (Local Winds chapter), you won't have to worry about this high density for long. The pressure inside your garage will increase so fast that it will blow out your walls and roof as if a bomb exploded. So don't leave your garage door (or your windows) open during a tornado.

$$\frac{\Delta \rho}{\Delta t} = - \left[\frac{\Delta(\rho U)}{\Delta x} + \frac{\Delta(\rho V)}{\Delta y} + \frac{\Delta(\rho W)}{\Delta z} \right] \quad (10.61)$$

where U , V , and W are the wind components in the x , y , and z directions, respectively, and t is time.

Be careful when calculating the wind gradients; calculate them as wind at location 2 minus wind at location 1, divided by distance at location 2 minus distance at location 1. Do not accidentally subtract 1 from 2 in the numerator, and then subtract 2 from 1 in the denominator, because it gives the wrong sign.

Incompressible Continuity Equation

Density at any fixed altitude changes only a little with temperature and humidity for most non-violent weather conditions. Therefore, we can neglect mass changes within the volume, compared to the inflow and outflow. The air is said to be **incompressible** when the density does not change ($\Delta \rho \approx 0$). This approximation fails in strong thunderstorm updrafts and tornadoes.

For incompressible flow, the left hand side and the advection terms of eq. (10.60) are zero. This requires inflow to balance outflow:

$$\frac{\Delta U}{\Delta x} + \frac{\Delta V}{\Delta y} + \frac{\Delta W}{\Delta z} = 0 \quad \bullet(10.62)$$

This continuity equation is illustrated in Fig. 10.26 for an example of inflow and outflow across the faces of a cube. The length of the grey arrows represents the strength of the wind components. Also, for this example $\Delta x = \Delta y = \Delta z$.

In the x -direction of this particular illustration, there is less wind (U) entering the cube than leaving ($U + \Delta U$). This is called **divergence**. For this case, ΔU is positive. In the z -direction (vertical), there is more air entering (W) than leaving ($W + \Delta W$), in Fig. 10.26. This is called **convergence**, and ΔW is negative. In the y -direction, the air entering (V) and leaving ($V + \Delta V$) are equal, so there is no convergence or divergence. For this example, ΔV is zero.

For this example shown in Fig. 10.26, the continuity equation is

$$(\text{positive}) + (0) + (\text{negative}) = 0$$

so we anticipate that mass is conserved. In the real atmosphere, the directions having convergence or divergence might differ from this example, but the sum must always equal zero. Namely convergence in one or two directions must be balanced by divergence in the other direction(s).

Horizontal divergence (D) is defined as

$$D = \frac{\Delta U}{\Delta x} + \frac{\Delta V}{\Delta y} \quad (10.63)$$

Negative values of D correspond to convergence. Plugging this definition into eq. (10.62) shows that vertical velocities increase with height where there is convergence:

$$\frac{\Delta W}{\Delta z} = -D \quad (10.64)$$

For situations such as circular isobars around a low pressure center, cylindrical coordinates are easier to use (Fig. 10.27). The continuity equation is then

$$\frac{2 \cdot V_{in}}{R} = \frac{\Delta W}{\Delta z} \quad \bullet(10.65a)$$

where R is the radius of the cylinder, and Δz is the cylinder depth. We assume that the radial inflow velocities V_{in} through the sides of the cylinder are equal everywhere. When V_{in} is positive (indicating horizontal inflow), then ΔW is also positive (indicating vertical outflow).

If a cylinder of air is at the ground where $W = 0$ at the cylinder bottom, then W at the cylinder top is:

$$W = (2 \cdot V_{in} \cdot \Delta z) / R \quad (10.65b)$$

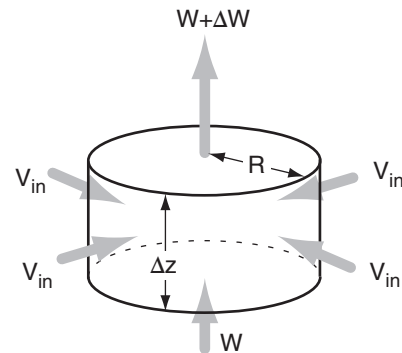

Figure 10.27
Mass conservation in cylindrical coordinates.

Solved Example

At a radius of 400 km from a low center, boundary layer winds have a 2 m/s component that crosses the circular isobars inward. If the boundary layer is 1 km thick, estimate the average vertical velocity out of the top of the boundary layer.

Solution

Given: $V_{in} = 2 \text{ m/s}$, $R = 400 \text{ km}$, $\Delta z = z_i = 1 \text{ km}$
Find: $W = ? \text{ m/s}$

$$\text{Use eq. (10.65b): } W = 2 \cdot V_{in} \cdot \frac{\Delta z}{R} = 2 \cdot (2 \text{ m/s}) \cdot \frac{1 \text{ km}}{400 \text{ km}} = 0.01 \text{ m/s}$$

Check: Units OK. Physics OK.

Discussion: For non-thunderstorm conditions, this magnitude of about 1 cm/s is typical for vertical velocities in the atmosphere. Such small velocities allow use of the hydrostatic assumption (see Chapter 1).

Boundary-Layer Pumping

Around low-pressure regions near the surface, turbulent drag causes horizontal inflow (convergence) and slower tangential winds within the boundary layer. There is no vertical air motion ($W = 0$) at the bottom of the boundary layer because of the ground. Thus, horizontal inflow in the boundary layer must be balanced by vertical outflow from the boundary-layer top.

This mechanism for creating mean upward motion is called **Ekman pumping** or **boundary-layer pumping**. The upward motion carries water vapor, which then condenses in the adiabatically cooled air, causing clouds and precipitation. Thus, low-pressure regions generally have foul weather.

Around high-pressure centers, turbulent drag causes horizontal outflow (divergence). This is balanced by downward motion called **subsidence** at the top of the boundary layer. Subsidence warms air adiabatically, thereby evaporating most clouds and causing fair weather in high-pressure regions.

In the section on the BLG wind, we defined V_{BLG} as the radial component of wind, which by definition equals the inflow velocity V_{in} for eq. 10.65 (see Fig. 10.28). Unfortunately, we were unable to find an analytical solution for V_{BLG} . However, there is an analytical solution available for V_{BL} from an earlier section, which is slightly greater than V_{BLG} . For the subsequent analysis, we will use $V_{in} \approx V_{BL}$, knowing that the result will be an upper limit on what are likely slower inflow velocities in the real atmosphere.

Assuming that the winds are relatively strong around lows, and that cloudy conditions preclude strong surface heating or cooling, we can assume that the boundary layer is statically **neutral**. For this situation, the inflow velocity across the isobars is given by eq. (10.41b).

Combining this inflow velocity with the cylindrical form of the continuity equation (10.65) allows us to calculate the vertical velocity W_{BL} at the top of the boundary layer (Fig. 10.28):

$$W_{BL} = \frac{2 \cdot b \cdot C_D \cdot G^2}{f_c \cdot R} \quad \bullet(10.66)$$

where R is the radius of curvature of the isobars around the low center, G is the geostrophic wind speed, f_c is the Coriolis parameter, and C_D (≈ 0.005 over land) is the drag coefficient for a neutral boundary layer.

The factor $b = \{ 1 - 0.5 \cdot [C_D \cdot G / (f_c \cdot z_i)] \}$ is from eq. (10.41b), where boundary-layer depth is z_i . For simplicity, the statically neutral **boundary-layer depth within a cyclone** can be approximated as

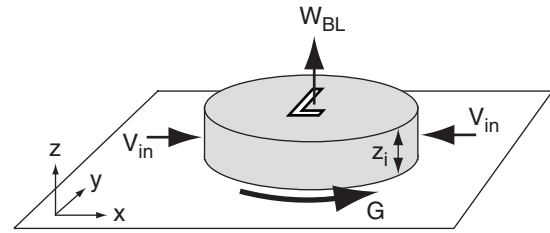

Figure 10.28
Convergence and updrafts in a cyclone.

$$z_i \approx \frac{G}{N_{BV}} \quad (10.67)$$

where N_{BV} is the Brunt-Väisälä frequency (see the Stability chapter) above the boundary layer. This allows b to be rewritten as: $b = \{ 1 - 0.5 \cdot [C_D \cdot N_{BV} / f_c] \}$. The approximation for boundary-layer cross-isobaric flow is valid only when $[C_D \cdot N_{BV} / f_c] < 1$.

The updraft velocity in eq. (10.66) depends on both the size and rotation speed of the cyclone. Vorticity is one measure of the combined effects of rotation speed and size. **Geostrophic relative vorticity** can be defined as

$$\zeta_g = \frac{2 \cdot G}{R} \quad (10.68)$$

which is a measure of the rotation of the air. More details of vorticity will be covered in the Global Circulation chapter.

Using the geostrophic vorticity in eq. (10.66) yields an alternative expression for the vertical velocity pumped out of the top of a cyclone:

$$W_{BL} = C_D \cdot \frac{G}{f_c} \cdot \zeta_g \cdot \left[1 - 0.5 \frac{C_D \cdot N_{BV}}{f_c} \right] \quad (10.69)$$

The terms outside of the brackets suggest that greater vertical velocities (and hence nastier storms) occur for stronger geostrophic winds (i.e., tighter packing of isobars) over rougher terrain, and where there is greater curvature of the cyclonic flow. Also, lower latitudes give smaller Coriolis parameters, which allow greater vertical velocity.

The term in square brackets shows that the fastest vertical velocity is expected in statically neutral flow (where $N_{BV} = 0$) above the boundary layer. Greater static stabilities cause weaker vertical velocities.

By utilizing the approximation for mixed-layer depth (eq. 10.67), an **internal Rossby radius of deformation** can be approximated as

Solved Example

A geostrophic wind of 10 m/s blows cyclonically around a low-center with radius of curvature of 1000 km. The latitude is such that $f_c = 0.0001 \text{ s}^{-1}$, and the drag coefficient is 0.005. The tropospheric lapse rate is standard above the BL.

What is the vertical velocity out of the top of the boundary layer? Also, estimate the boundary-layer depth, geostrophic relative vorticity, and internal Rossby radius.

Solution

Given: $G = 10 \text{ m/s}$, $R = 10^6 \text{ m}$, $f_c = 0.0001 \text{ s}^{-1}$,
 $C_D = 0.005$, $N_{BV} = 0.0113 \text{ s}^{-1}$ (from a previous solved example using the standard atmos.)
 Find: $z_i = ? \text{ m}$, $\zeta_g = ? \text{ s}^{-1}$, $\lambda_R = ? \text{ km}$, $W_{BL} = ? \text{ m/s}$
 Assume: tropospheric depth $z_T = 11 \text{ km}$

Use eq. (10.67):
 $z_i \approx G/N_{BV} = (10 \text{ m/s})/(0.0113 \text{ s}^{-1}) = \mathbf{885 \text{ m}}$

Use eq. (10.68):
 $\zeta_g = \frac{2 \cdot (15 \text{ m/s})}{5 \times 10^5 \text{ m}} = \mathbf{2 \times 10^{-5} \text{ s}^{-1}}$

Use eq. (10.70):
 $\lambda_R \approx \frac{(15 \text{ m/s})}{(0.0001 \text{ s}^{-1})} \cdot \frac{11 \text{ km}}{1.327 \text{ km}} = \mathbf{1243 \text{ km}}$

First check that $[C_D \cdot N_{BV} / f_c] < 1$.
 $[0.005 \cdot (0.0113 \text{ s}^{-1}) / (0.0001 \text{ s}^{-1})] = 0.565 < 1$. OK.

Use eq. (10.71): $W_{BL} =$
 $0.004 \cdot \frac{(1.327 \text{ km})}{(11 \text{ km})} \cdot (1.243 \times 10^6 \text{ m}) \cdot (6 \times 10^{-5} \text{ s}^{-1})$
 $\cdot \left[1 - 0.5 \cdot (0.004) \cdot \frac{1243 \text{ km}}{11 \text{ km}} \right]$
 $= (0.01 \text{ m/s}) \cdot [0.718] = \mathbf{0.0072 \text{ m/s}}$

Check: Units OK. Physics OK.

Discussion: This vertical velocity of 7.2 mm/s is typical of synoptic circulations. Although weak, it is sufficient to lift air to cause condensation, releasing latent heat which allows stronger buoyant updrafts within the clouds.

$$\lambda_R \approx \frac{G}{f_c} \cdot \frac{z_T}{z_i} \tag{10.70}$$

where z_i is the boundary-layer depth and z_T is the depth of the troposphere. The internal Rossby radius of deformation is discussed in more detail in the Global Circulation chapter, and an external Rossby radius is given in the Air masses & Fronts chapter.

Thus, an alternative form for the vertical velocity equation can be written using the Rossby radius of deformation:

$$W_{BL} = C_D \cdot \frac{z_i}{z_T} \cdot \lambda_R \cdot \zeta_g \cdot \left[1 - 0.5 \cdot C_D \cdot \frac{\lambda_R}{z_T} \right] \tag{10.71}$$

KINEMATICS

Kinematics is the study of patterns of motion, without regard to the forces that cause them. We will focus on horizontal divergence, vorticity, and deformation. All have units of s^{-1} .

We have already encountered **divergence**, D , the spreading of air:

$$D = \frac{\Delta U}{\Delta x} + \frac{\Delta V}{\Delta y} \tag{10.72}$$

Figure 10.29a shows an example of pure divergence. Its sign is positive for divergence, and negative for **convergence** (when the wind arrows point toward a common point).

Vorticity describes the rotation of air (Fig. 10.29b). The relative vorticity, ζ_r , is given by:

$$\zeta_r = \frac{\Delta V}{\Delta x} - \frac{\Delta U}{\Delta y} \tag{10.73}$$

The sign is positive for counterclockwise rotation (i.e., cyclonic rotation in the N. Hemisphere), and negative for clockwise rotation. Vorticity is discussed in greater detail in the Global Circulation chapter. Neither divergence nor vorticity vary with rotation of the axes — they are **rotationally invariant**.

Two types of **deformation** are stretching deformation and shearing deformation (Figs. 10.29c & d). **Stretching deformation**, F_1 , is given by:

$$F_1 = \frac{\Delta U}{\Delta x} - \frac{\Delta V}{\Delta y} \tag{10.74}$$

The axis along which air is being stretched (Fig. 10.29c) is called the **axis of dilation** (x axis in this

example), while the axis along which air is compressed is called the **axis of contraction** (y axis in this example).

Shearing deformation, F_2 , is given by:

$$F_2 = \frac{\Delta V}{\Delta x} + \frac{\Delta U}{\Delta y} \quad (10.75)$$

As you can see in Fig. 10.29d, shearing deformation is just a rotated version of stretching deformation. The **total deformation**, F , is:

$$F = [F_1^2 + F_2^2]^{1/2} \quad (10.76)$$

Deformation often occurs along fronts. Most real flows exhibit combinations of divergence, vorticity, and deformation.

MEASURING WINDS

For weather stations at the Earth's surface, wind direction can be measured with a **wind vane** mounted on a vertical axel. **Fixed vanes** and other shapes can be used to measure wind speed, by using strain gauges to measure the minute deformations of the object when the wind hits it.

The generic name for a wind-speed measuring device is an **anemometer**. A **cup anemometer** has conic- or hemispheric-shaped cups mounted on spokes that rotate about a vertical axel. A **propellor anemometer** has a propellor mounted on a horizontal axel that is attached to a wind vane so it always points into the wind. For these anemometers, the rotation speed of the axel can be calibrated as a wind speed.

Other ways to measure wind speed include a **hot-wire** or **hot-film anemometer**, where a fine metal wire is heated electrically, and the power needed to maintain the hot temperature against the cooling effect of the wind is a measure of wind speed. A **pitot tube** that points into the wind measures the dynamic pressure as the moving air stagnates in a dead-end tube. By comparing this dynamic pressure with the static pressure measured by a different sensor, the pressure difference can be related to wind speed.

Sonic anemometers send pulses of sound back and forth across a short open path between two opposing transmitters and receivers of sound. The speed of sound depends on both temperature and wind speed, so this sensor can measure both. Tracers such as smoke, humidity fluctuations, or clouds can be **tracked** photogramatically from the ground

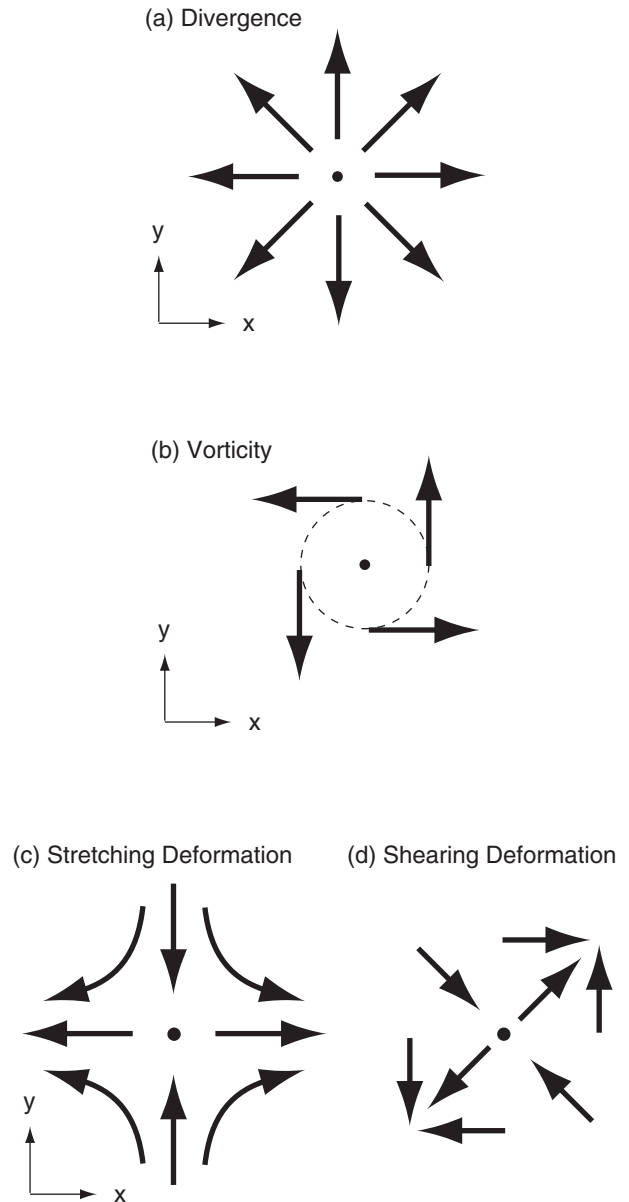

Figure 10.29

Kinematic flow-field definitions. Black arrows represent wind velocity.

or from remote sensors such as laser radars (**lidars**) or satellites, and the wind speed then estimated from the change of position of the tracer between successive images.

Measurements of wind vs. height can be made with **rawinsonde balloons** (using a GPS receiver in the sonde payload to track horizontal drift of the balloons with time), **dropsondes** (like rawinsondes, only descending by parachute after being dropped from aircraft), **pilot balloons** (carrying no payload, but being tracked instead from the ground using radar or theodolites), **wind profilers**, **Doppler weather radar** (see the Remote Sensing chapter), and via anemometers mounted on aircraft.

SUMMARY

Pressure-gradient force can start winds moving, and can change wind direction and speed. This force points from high to low pressure on a constant altitude chart (such as at sea-level), or points from high to low heights on an isobaric chart (such as the 50 kPa chart).

Once the air is moving, other forces such as turbulent drag or Coriolis force also act on the air. Coriolis force is an apparent force that accounts for our moving frame of reference on the rotating Earth. Turbulent drag is important only near the ground, in the boundary layer. The relationship between forces and acceleration of the winds is given by Newton's second law of motion.

When all forces balance, the winds are steady. In regions of straight isobars above the boundary layer, pressure-gradient and Coriolis forces balance to cause winds that are geostrophic. Around highs or lows, there are slight imbalances associated with centrifugal force, which causes steady-state gradient winds. In the boundary layer, winds are slower than either geostrophic or gradient because of turbulent drag. In tornadoes and waterspouts, centrifugal and pressure gradient forces nearly balance to create the intense cyclostrophic wind. In oceans, currents can inertially flow in a circle.

The two most important force balances at mid-latitudes are hydrostatic balance in the vertical, and geostrophic balance in the horizontal.

Outside of thunderstorms, winds are well described by incompressible mass continuity. Thus, mechanisms that cause motion in one direction (horizontal or vertical) will also indirectly cause motions in the other direction as the air tries to maintain continuity, resulting in a circulation. **Kinematics** is the word that describes the behavior and effect of winds (such as given by the continuity

equation), while the word **dynamics** describes how forces cause winds (as given by Newton's second law).

Threads

Forces cause winds, and winds flow over mountains to form mountain waves and lenticular clouds (Chapter 17). Winds embody the global circulation (Chapter 11), which moves air masses around to create fronts (Chapter 12), extratropical cyclones (Chapter 13) and our global climate (Chapter 21). The equations of motion are solved every day on large computers to make the daily weather forecasts (Chapter 20). The interplay between buoyancy (Chapter 5) and dynamics creates phenomena such as thunderstorms, tornadoes (Chapters 14 and 15), and hurricanes (Chapter 16). Winds advect air pollutants from place to place (Chapter 19).

Not only do winds advect temperature (Chapter 3), but horizontal temperature variations cause horizontal pressure variations via the hypsometric equation (Chapter 1), thereby driving the jet-stream winds. Winds riding over colder air masses carry water vapor (Chapter 4), some of which can condense to make clouds (Chapter 6) and precipitation (Chapter 7). Clouds imbedded in the air will move horizontally with the air, and can be tracked by satellite (Chapter 8) to estimate the wind speed and direction. The complexity of the atmosphere is becoming apparent.

EXERCISES

Numerical Problems

N1. Plot the wind symbol for winds with the following directions and speeds:

- | | | |
|----------------|----------------|-----------------|
| a. N at 5 kt | b. NE at 35 kt | c. E at 65 kt |
| d. SE at 12 kt | e. S at 48 kt | f. SW at 105 kt |
| g. W at 27 kt | h. NW at 50 kt | i. N at 125 kt |

N2. Find the acceleration of a 75 kg person when pushed by a force (N) of

- | | | | | | |
|--------|--------|--------|---------|---------|-------|
| a. 1 | b. 2 | c. 5 | d. 10 | e. 20 | f. 50 |
| g. 100 | h. 200 | i. 500 | j. 1000 | k. 2000 | |

N3. If the initial velocity of an object is zero, find the final velocity after 100 s for an applied net force per unit mass of:

- | | |
|------------|-------------------------|
| a. 5 N/kg | b. 10 m·s ⁻² |
| c. 15 N/kg | d. 20 m·s ⁻² |
| e. 25 N/kg | f. 30 m·s ⁻² |
| g. 35 N/kg | h. 40 m·s ⁻² |
| i. 45 N/kg | j. 50 m·s ⁻² |

N4. Find the advective “force” per unit mass given the following wind components (m/s) and horizontal distances (km):

- $U=10, \Delta U=5, \Delta x=3$
- $U=6, \Delta U=-10, \Delta x=5$
- $U=-8, \Delta V=20, \Delta x=10$
- $U=-4, \Delta V=10, \Delta x=-2$
- $V=3, \Delta U=10, \Delta y=10$
- $V=-5, \Delta U=10, \Delta y=4$
- $V=7, \Delta V=-2, \Delta y=-50$
- $V=-9, \Delta V=-10, \Delta y=-6$

N5. What is the pressure-gradient force per unit mass between Seattle, WA, and Corvallis, OR (about 340 km south of Seattle), if sea-level pressure is 98.4 kPa in Seattle and has the following pressure (kPa) in Corvallis?

- 98.6
- 98.8
- 99.0
- 99.2
- 99.4
- 99.6
- 99.8
- 100.0
- 100.2
- 100.4
- 100.6
- 100.8
- 101.0
- 101.2
- 101.4

N6. Given $U = -5$ m/s and $V = 10$ m/s, find the components of centrifugal force around a 800 km diameter:

- low in the southern hemisphere
- high in the northern hemisphere
- high in the southern hemisphere
- low in the northern hemisphere

N7. Calculate the Coriolis parameter for

- Munich, Germany
- Oslo, Norway
- Madrid, Spain
- Chicago, USA
- Buenos Aires, Argentina
- Melbourne, Australia
- Vancouver, Canada
- Beijing, China
- Moscow, Russia
- Tokyo, Japan
- (your town)

N8. For Chicago, find the Coriolis force per unit mass in the N. Hemisphere for:

- $U = 10$ m/s
- $V = 5$ m/s
- $U = 3$ m/s
- $U = -10$ m/s
- $V = -5$ m/s
- $U = 8$ m/s
- $U = -3$ m/s
- $V = -8$ m/s
- $V = 40$ m/s

N9. For a neutral boundary layer, find the turbulent drag force per unit mass over a forest for

- $U = 5$ m/s and $V = 25$ m/s
- $U = -10$ m/s and $V = 5$ m/s
- $U = 5$ m/s and $V = -15$ m/s
- $U = -5$ m/s and $V = -5$ m/s
- $U = -40$ m/s and $V = 5$ m/s

- $U = 5$ m/s and $V = 35$ m/s
- $U = 25$ m/s and $V = -2$ m/s
- $U = 0$ m/s and $V = 10$ m/s

N10. For a statically unstable boundary layer, find the turbulent drag force per unit mass, given a buoyant velocity scale of 60 m/s and

- $U = 5$ m/s and $V = 1$ m/s
- $U = -1$ m/s and $V = 3$ m/s
- $U = 2$ m/s and $V = -4$ m/s
- $U = -2$ m/s and $V = -1$ m/s
- $U = -4$ m/s and $V = 0$ m/s
- $U = 5$ m/s and $V = 3$ m/s
- $U = 5$ m/s and $V = -2$ m/s
- $U = 0$ m/s and $V = 2$ m/s

N11. Draw a northwest wind of 5 m/s in the S. Hemisphere on a graph, and show the directions of forces acting on it. Assume it is in the boundary layer.

- pressure gradient
- Coriolis
- centrifugal
- drag

N12. What is the geostrophic wind speed at a height where $\rho = 0.7$ kg/m³, $f_c = 10^{-4}$ s⁻¹, and the pressure gradient (kPa/100 km) magnitude is:

- 0.1
- 0.2
- 0.3
- 0.4
- 0.5
- 0.6
- 0.7
- 0.8
- 0.9
- 1.0
- 1.1
- 1.2
- 1.3
- 1.4
- 1.5

N13. At a latitude of 60°N, find the geostrophic wind given a height gradient (m/km on a constant pressure surface) of:

- 0.1
- 0.2
- 0.3
- 0.4
- 0.5
- 0.6
- 0.7
- 0.8
- 0.9
- 1.0
- 1.1
- 1.2
- 1.3
- 1.4
- 1.5

N14. If the geostrophic wind around a high is 10 m/s, then what is the gradient wind speed, given $f_c = 10^{-4}$ s⁻¹ and a radius of curvature of:

- 800 km
- 500 km
- 600 km
- 1000 km
- 2000 km
- 1500 km
- 700 km
- 1200 km
- 900 km

N15. Find the boundary layer winds given $U_g = 5$ m/s, $V_g = 5$ m/s, $z_i = 1500$ m, and $f_c = 10^{-4}$ s⁻¹. Also, what angle do the winds cross the isobars? This is a statically neutral boundary layer. Use $C_D =$

- 0.002
- 0.004
- 0.006
- 0.008
- 0.010
- 0.012
- 0.014
- 0.016
- 0.018
- 0.019

N16. Same as previous problem, but for an unstable boundary layer with w_B (m/s) of:

- 75
- 100
- 50
- 200
- 150
- 225
- 125
- 250
- 175
- 275

N17(S). Recompute M_{BLG} as in the solved example in the Boundary Layer Gradient Wind section, but with the following changes:

- a. $G = 10$ m/s b. $z_i = 2$ km c. $C_D = 0.002$
 d. $R = 1000$ km e. $f_c = 2 \times 10^{-4} \text{ s}^{-1}$
 f. $G = 15$ m/s g. $z_i = 1.5$ km h. $C_D = 0.005$
 i. $R = 1500$ km j. $f_c = 1.5 \times 10^{-4} \text{ s}^{-1}$

N18. Given a pressure gradient of 0.5 kPa/m, compute the cyclostrophic wind at the following radii (m):

- a. 10 b. 12 c. 14 d. 16 e. 18
 f. 20 g. 22 h. 24 i. 26 j. 28 k. 30

N19. For an inertial wind, find the radius of curvature (km) and the time period (h) needed to complete one circuit, given $f_c = 10^{-4} \text{ s}^{-1}$ and an initial wind speed (m/s) of:

- a. 1 b. 2 c. 3 d. 4 e. 6 f. 7 g. 8 h. 9
 i. 10 j. 11 k. 12 m. 13 n. 14 o. 15

N20. Find the antitropical wind for the conditions of exercise N15.

N21. The boundary layer is 2 km thick. At a radius of 200 km from a low center, estimate the average vertical velocity through the top of the boundary layer (BL), given an inward radial wind component (m/s) of:

- a. 2 b. 1.5 c. 1.2 d. 1.0
 e. -0.5 f. -1 g. -2.5 h. 3 i. 0.8 j. 0.2

N22. Estimate boundary layer depth within a cyclone given an isothermal environment above the boundary layer, and a geostrophic wind (m/s) near the surface of:

- a. 5 b. 10 c. 15 d. 20 e. 25
 f. 30 g. 35 h. 40 i. 3 j. 8 k. 2 l. 1

N23(S). For a 1 km thick boundary layer over a surface of drag coefficient 0.003, plot the vertical velocity due to boundary-layer pumping as a function of geostrophic wind speed, but for only wind speeds within the valid range for that eq. Plot separate curves for the following radii (km) of curvature:

- (Assume a latitude of 45° , & standard atmosphere)
 a. 500 b. 1000 c. 2000 d. 3000 e. 4000
 (Assume a latitude of 60° , & standard atmosphere)
 f. 500 g. 700 h. 900 i. 1500 j. 2500

N24. Estimate the value of internal Rossby radius of deformation at latitude 60°N for a tropospheric depth of 11 km and geostrophic wind speed of 15 m/s. Assume a boundary-layer depth of

- a. 500 m b. 1 km c. 2 km d. 750 m e. 250 m
 f. 1.5 km g. 2.5 km h. 3 km i. 3.5 km j. 100 m

N25. Given $\Delta U/\Delta x = \Delta V/\Delta x = (5 \text{ m/s}) / (500 \text{ km})$, find the divergence, vorticity, and total deformation for

$(\Delta U/\Delta y, \Delta V/\Delta y)$ in units of (m/s)/(500 km) as given below:

- a. (-5, -5) b. (-5, 0) c. (0, -5) d. (0, 0) e. (0, 5)
 f. (5, 0) g. (5, 5) h. (-5, 5) i. (5, -5)

Understanding & Critical Evaluation

U1. Compare eq. (10.1) with (1.24), and discuss.

U2. Can eqs. (10.6) be used to make a forecast if the initial conditions (i.e., the current winds) are not known? Discuss.

U3. If all of the net forces (eq. 10.7) are zero, does that mean that the wind speeds (eq. 10.5) are zero? Explain.

U4. Eqs. (10.8) suggest that winds can advect winds. How is that possible?

U5. In eqs. (10.8), why does advection depend on the gradient of winds (e.g., $\Delta U/\Delta x$) across the Eulerian domain, rather than on just the value of wind that is being blown into the domain?

U6. In Fig. 10.5, and on weather maps, what is the relationship between packing of isobars (i.e., the number of isobars that cross through a square cm of weather map) and the pressure gradient?

U7. In the N. Hemisphere, the pressure gradient points from high to low pressure. Which way does it point in the S. Hemisphere?

U8. Eqs. (10.9) give the horizontal components of the pressure-gradient force. Combine those equations vectorially to show that the vector direction of the pressure-gradient force is indeed perpendicular to the isobars and pointing toward lower pressure, for any arbitrary isobar direction such as shown in Fig. 10.5.

U9. Eqs. (10.13) give the horizontal components of centrifugal force. Combine those equations vectorially to show that the vector direction of centrifugal force is indeed outward from the center of rotation, and is proportional to the square of the tangential velocity.

U10. An air parcel at rest (relative to the Earth) near the equator experiences greater tangential velocity due to the Earth's rotation than do air parcels at higher latitudes. Yet the Coriolis parameter is zero at the equator. Why?

U11. Eqs. (10.17) give the horizontal components of the Coriolis force. Combine those equations vectorially to show that the vector direction of the Coriolis force is indeed 90° to the right of the wind direction, for any arbitrary wind direction such as the two shown in Fig. 10.6.

U12. For the subset of eqs. (10.1 - 10.17) defined by your instructor, rewrite them for the S. Hemisphere.

U13. Eqs. (10.19) give the horizontal components of the turbulent drag force.

a. Combine those equations vectorially to show that the vector direction of the drag force is indeed opposite to the wind direction, for any arbitrary wind direction.

b. Show that the magnitude of the drag force is proportional to the square of the wind speed, M , for statically neutral conditions.

U14. Compare the values of the turbulent transport velocity during windy (statically neutral) and convective (statically unstable) conditions. Discuss.

U15. Plug eqs. (10.26) into (10.27) to find the vector speed and direction (see Chapter 1) of the geostrophic wind as a function of the vector pressure gradient.

U16. Re-derive the geostrophic wind eqs. (10.26) for the S. Hemisphere.

U17. Derive eqs. (10.29) from eqs. (10.26).

U18. The geostrophic wind approaches infinity as the equator is approached (see Fig. 10.10), yet the winds in the real atmosphere are not infinite there. Why?

U19. Verify that eq. (10.33) is indeed a solution to the gradient wind eqs. (10.31).

U20. Verify that eqs. (10.34) are solutions to eq. (10.33).

U21. Imagine an idealized weather map that had a single high pressure center next to a single low pressure center. Further, suppose that if you were to draw a line through those two centers, that the pressure variation along that line would be the same as Fig. 10.14. Given that information, and assuming circular cyclones and anticyclones, draw isobars on the weather map at ± 0.5 kPa increments, starting at 100 kPa. Comment on the packing of (i.e., how closely spaced are) isobars near the centers of the cyclone and anticyclone.

U22. a. Is there any limit on the strength of the pressure gradient that can occur just outside of the center of cyclones? (Hint: consider Fig. 10.14)

b. What controls this limit?

c. What max winds are possible around cyclones?

U23. Calculate the geostrophic and gradient winds, as appropriate, at a number of locations using the height contours plotted in Fig. 10.3. Compare them to the observed winds and comment.

U24. What is implicit about the implicit solution (eq. 10.39) for the boundary-layer wind?

U25. How accurate are the approximate boundary layer wind solutions (eq. 10.41)? Under what conditions are the approximate solutions least accurate? (Hint: compare with an iterative solution to the implicit equations 10.39).

U26. Why is an exact explicit solution possible for the steady-state winds in the unstable boundary layer, but not for the neutral boundary layer?

U27. Verify that eqs. (10.42) are indeed exact solutions to (10.39) or (10.38).

U28(S). a. Recreate on a spreadsheet the solved example for the boundary-layer gradient winds.

b. Recreate the checks of that equation for the special cases where it reduces to the geostrophic wind, gradient wind, and boundary-layer wind.

c. Compare the results from (b) against the respective analytical solutions (which you must compute yourself).

d. Can the analytical solutions for the gradient wind and the (neutral) boundary layer wind be combined to yield an approximate analytical solution to the BLG winds. If so, what are the limitations, and the magnitude of the errors. (Hint: Try substituting M_{\tan} in place of G in the equations for boundary layer wind.)

U29. Photocopy Fig. 10.13, and enhance the copy by drawing additional vectors for the boundary-layer wind and the BLG wind. Make these vectors be the appropriate length and direction relative to the geostrophic and gradient winds that are already plotted.

U30. Verify that the cyclostrophic winds are indeed a solution to the governing equations (10.45).

U31. Re-derive the equations for cyclostrophic wind, but in terms of height gradient on a constant pressure surface, instead of pressure gradient along a constant height surface. [Hint: Compare eqs. (10.29) to (10.26).]

U32. What aspects of the *Approach to Geostrophy* Focus Box are relevant to the inertial wind? Discuss.

U33. a. Derive eq. (10.66) based on geometry and mass continuity (total inflow = total outflow).

b. For horizontal winds, we know that an increased drag coefficient will reduce wind speed. Why in eq. (10.66) does an increased drag coefficient cause increased vertical wind speed?

c. When considering that factor b in eq. (10.66) is a negative function of the drag coefficient, does your answer to part (b) change?

U34. The paragraph after eq. (10.69) gives a physical interpretation of the equation. Show how that interpretation was reached, by examining each term in the equation and discussing its impact on W .

U35. Given eq. (10.70), determine the physical meaning of the internal Rossby radius of deformation by how it affects the various terms in (10.71).

U36. Regarding horizontal balances of forces, if only Coriolis and turbulent-drag forces were active, speculate on the nature of the resulting wind.

U37. Modify eqs. (10.66) through (10.71) if necessary, to describe the boundary-layer pumping around highs (anticyclones) rather than around lows (cyclones). Discuss the significance of your equations.

U38. Rewrite the total deformation as a function of divergence and vorticity. Discuss.

Web-Enhanced Questions

W1. Search the web for historical discussions of Isaac Newton, and summarize what you find. What did you find most unusual or interesting?

W2. Search the web for “Coriolis Force”, to find sites that show animations of the movement of objects in a rotating coordinate system. Tabulate a list of the best sites.

W3. a. Search the web for a current sea-level weather map that covers your area, and which includes isobars. Measure the distance (km) between isobars, and compute the pressure gradient force.

b. Same as (a), but do this for several days in a row. Then plot a graph of how the pressure gradient changes with time over your location.

W4. Search the web for 50 kPa (500 mb) weather maps that cover part of the S. Hemisphere. Compute the geostrophic and gradient wind speeds and directions in regions of straight and curved isobars, respectively, and compare with upper-air observations. Discuss the differences between these winds and corresponding winds in the N. Hemisphere.

W5. Find a current 50 kPa (= 500 mb) weather map (or other map as specified by your instructor) that has height contours already drawn on it. Look for a region in the map where the isobars are nearly straight.

a. Compute the geostrophic wind speed components, and the total geostrophic wind speed vector (speed and direction).

b. If upper-air (rawinsonde) observations are available near your area, compare the measured winds with the geostrophic value computed from part (a).

c. If there are multiple regions of nearly straight isobars at different latitudes in your weather map, see how the observed winds in these regions vary with latitude, and compare with the expected latitudinal variation of geostrophic wind (as from Fig. 10.10).

W6. a. Same as W5, except look for a region on the map where the isobars are curving in a cyclonic (counterclockwise in the N. Hemisphere) direction when following along with the wind direction. Compute the gradient wind for this case.

b. Same as (a) but for anticyclone (clockwise) turning winds.

c. Compare the measured winds from rawinsondes to the theoretical winds from (a) and (b). Confirm that the gradient winds (both theoretical and observed) are slower than geostrophic around lows, and faster around highs.

W7. a. Find a sea-level weather map from the web that has isobars drawn on it. Look for a day or a region where there are neighboring regions of strong high and low pressure. Print this map, and draw a straight line connecting the centers of the high and the low. Extend this line well past the centers of the high and low. Using the isobars that cross your drawn line, find how pressure varies with distance between the high and low, and plot the results similar to Fig. 10.14.

b. If you set the location of the center of the high as the origin of your coordinate system, check

whether the shape of the pressure curve agrees with eq. (10.37b). Confirm that the pressure variation across a low-pressure center can have a cusp, while that across a high center cannot.

W8. Search the web for a weather map at 50 kPa (500 mb) or any other altitude above the boundary layer, that includes the equator. Find a region of relatively straight isobars near the equator, and compute the geostrophic wind speed based on the plotted pressure gradient. Compare this theoretical wind with observed upper-air winds for the same altitude. Why don't the observations agree with the theory?

W9. Find a current sea-level weather map from the web, that shows both wind direction (such as the wind symbol on surface station observations), and isobars.

a. For a region of the map where the isobars are relatively straight, and hopefully over non-mountainous and non-coastal terrain, confirm that the observed boundary-layer winds indeed cross the isobars at some small angle from high to low pressure. What is the average angle?

b. For a region where the isobars are curved around a high or low, confirm that the winds spiral in towards the center of the low, and out from the center of a high.

c. Around either the high or low, estimate the average value of the component of wind that represents inflow or outflow from the low or high. Use that value of V_{in} (or V_{out}) in eq. (10.65) to compute the vertical velocity at the top of the boundary layer.

d. Based on the inward or outward component of velocity from (c), estimate the drag force acting on the air. If this calculation is for flow around a low where the winds are relatively fast, find the value of the drag coefficient C_D for statically neutral conditions.

W10. a. If it is hurricane season, search the web for a weather map that is just above the top of the boundary layer (85 kPa or 850 mb might be good enough), but which is well below the altitude of the 60 kPa pressure. Look for a map (either observed or forecast) that has the height contours around the hurricane on this pressure surface (85 kPa). Find the location just outside of the eye where the height contours are packed closest together, and calculate the pressure gradient there. Then use that pressure gradient to compute the cyclostrophic wind, and compare your theoretical value with the observed upper-air values at that height.

b. Do the same as (a), but using a sea-level weather map showing the isobars. Also comment on the effect of boundary layer drag.

Synthesis Questions

S1. Suppose Newton's second law of motion was not a function of mass. How would the motion of bullets, cannon balls, and air parcels be different, if at all?

S2. What if Newton's second law of motion stated that velocity was proportional to force/mass. How would weather and climate be different, if at all?

S3. What if wind could not advect itself. How would the weather and climate be different, if at all?

S4. Suppose that pressure-gradient force was along isobars, rather than perpendicular to them. Describe how winds would be different, how weather maps would be different, and how this might affect the weather and climate, if at all.

S5. There is some debate in the literature that our understanding of Coriolis force might be incorrect. We think that Coriolis force is an apparent force. Can an apparent force change the momentum and kinetic energy of air parcels? If so, would this violate Newton's laws when viewed from a non-rotating frame? Discuss. (Hint: look for a series of descriptive articles by Anders Persson that appeared in *Weather* magazine starting in year 2000.)

S6. Fig. 10.7 shows wind shear across the top of the boundary layer, where subgeostrophic winds in the boundary layer change to geostrophic winds above the boundary layer. The shear can exist because a strongly statically stable layer of air caps the boundary layer. If such a stable capping inversion did not exist, how might the wind profile be different over the depth of the troposphere?

S7. Suppose that turbulent drag force acted 90° to the right of the wind direction in the boundary layer. Discuss how the boundary-layer winds would work around highs and lows, and in regions of straight isobars. How would the weather and climate be different, if at all?

S8. Suppose that the boundary-layer drag force did not increase with velocity (in the case of an unstable boundary layer) or with velocity squared (in the case of a neutral boundary layer), but was constant regardless of wind speed. How would the boundary layer winds, weather, and climate change, if at all?

- S9. What if there were no Coriolis force? How would winds, weather, and climate be different, if at all?
- S10. On our present world where we perceive a Coriolis force, are there situations where it is possible for wind to blow directly high to low pressure, rather than more-or-less parallel to the isobars? Describe such scenarios.
- S11. What if geostrophic winds could turn around high or low pressure systems without feeling centripetal or centrifugal force. How would the weather and climate be different, if at all?
- S12. Suppose that cusps in pressure were allowed at high-pressure centers as well as at low pressure centers (see Fig. 10.14) so that strong pressure gradients could exist near the center of both types of pressure centers. Describe how the winds, weather, and climate might be different, if at all?
- S13. Suppose that the Earth's surface were frictionless. How would the weather and climate be different, if at all?
- S14. Suppose that the tropopause acted like a rigid lid on the troposphere, and that the air at the top of the troposphere felt frictional drag against this rigid lid. How would the winds, weather, and climate be different, if at all?
- S15. What if the Earth were a flat spinning disk instead of a spinning sphere. How would the weather and climate be different, if at all?
- S16. Suppose the Earth's rotation were twice as fast as now. How would the weather and climate change, if at all?
- S17. Suppose that the axis of the Earth's rotation were along a radial line drawn from the sun (i.e., in the plane of the ecliptic), rather than being more or less perpendicular to the ecliptic plane. How would the weather and climate be different, if at all?
- S18. Suppose the Earth did not rotate. How would the winds, weather, and climate be different, if at all?
- S19. Why is incompressibility such a good approximation for the real atmosphere? How does the atmosphere react to density changes, that might help ensure little density change? (Hint: consider the first solved example in the continuity equation section.)
- S20. Extend the discussion of the Focus box on Coriolis Force by deriving the magnitude of the Coriolis force for an object moving
a. westward b. southward
- S21. For zonal (east-west) winds, there is also a vertical component of Coriolis force. Using your own diagrams similar to those in the Focus box on Coriolis Force, show why it can form. Estimate its magnitude, and compare the magnitude of this force to other typical forces in the vertical. Show why a vertical component of Coriolis force does not exist for meridional (north-south) winds.
- S22. What if a cyclostrophic-like wind also felt drag near the ground? This describes conditions at the bottom of tornadoes. Write the equations of motion for this situation, and solve them for the tangential and radial wind components. Check that your results are reasonable compared with the pure cyclostrophic winds. How would the resulting winds affect the total circulation in a tornado? As discoverer of these winds, name them after yourself.
- S23. The time duration of many weather phenomena are related to their spatial scales, as shown by eq. (10.53) and Fig. 10.24. Why do most weather phenomena lie near the same diagonal line on a log-log plot? Why are there not additional phenomena that fill out the relatively empty upper and lower triangles in the figure? Can the distribution of time and space scales in Fig. 10.24 be used to some advantage?